

**DEPARTMENT OF MINES, MINERALS AND ENERGY  
DIVISION OF MINERAL MINING**



**SURFACE BLASTER'S CERTIFICATION  
STUDY GUIDE**

**July 2009**  
(updated March 2010)

Copyright 2009 Commonwealth of Virginia

Commonwealth of Virginia  
Department of Mines, Minerals and Energy  
Division of Mineral Mining  
900 Natural Resources Drive, Ste. 400  
Charlottesville, VA 22903  
(434) 951-6310



## TABLE OF CONTENTS

Introduction.....	1
Section	
1 Duties and Responsibilities of the Certified Blaster .....	3-8
2 Hazard Recognition in Blasting .....	9-18
3 Basic Knowledge of Blasting.....	19-44
4 Blasting Design/Control.....	45-54
5 Blasting Effects .....	55-76
6 State Law and Regulations applicable to Surface Blasting Certification.....	77-88
Appendix.....	
I. Blasting Related Accident Abstracts .....	A2-A10
A. Injury/Fatality Cases	
B. Flyrock Incidents	
II. Associated Articles.....	A11-A16
III. Example Record Forms .....	A17-A22
IV. Suggested Blasting Equipment Lists.....	A23-A24
V. Safety Talk Outlines/Summaries.....	A25-A30
VI. Flyrock Prevention Communication Memorandum.....	A311-A32
VII. Flyrock Hazard Alert.....	A33
VIII. Bibliography .....	A34

This Guide has been developed for the purpose of preparing individuals for the Virginia Board of Mineral Mining Examiner’s Surface Blaster certification examination. This Guide is not intended to cover all particular circumstances surrounding the design, loading, and firing of explosives. The Division of Mineral Mining assumes no responsibility for the specific application of the material presented in this Guide.



## INTRODUCTION

This study guide was prepared to assist in providing basic blasting knowledge and understanding of safe practices necessary to perform the duties of a surface (mineral mine) blaster. Every blaster must possess knowledge of theory and principles of explosives, as well as practical know-how in their storage, handling, transportation, and use. More importantly, every blaster must be aware of what is necessary to prepare and conduct good blasting operations that protect the health and safety of miners and other individuals. Considerations for the adjacent community and the environment must also be a top priority.

Mineral Miners must have one (1) year of blasting experience on a surface mineral mine working under the direct supervision of a certified blaster (or equivalent experience approved by Division of Mineral Mining) in order to qualify for State certification. A minimum score of 80% is required on each section of the State examination to obtain certification.

The use of explosives in the mineral mining industry continues to present a potentially serious risk of injury and death to miners. The prevention of such accidents depends, to a large extent, on two factors: (1) the knowledge and experience of persons responsible for the use of explosives and (2) well defined safety precautions to guide mine operators and miners in the safe conduct of blasting operations.

The prevention of blasting related accidents depends on careful planning and the faithful observance of proper blasting procedures and practices. Even the slightest abuse or misdirection of explosives can result in serious injury or death to mining personnel or the public.

Two cardinal rules must be acknowledged and understood when using explosives:

1. A blaster's most important responsibility is safety.
2. The safety of every blast is dependent on the people involved.

A surface blaster must have essential training and experience that not only develops skills, but proper safety attitudes as well. The same holds true for other mining personnel who handle explosives or assist in any way with blasting operations. All persons involved must know what is, and what is not safe...and why. Explosives safety is a habit that can only be developed through training and the repetition of proper procedures.

A surface blaster shall always follow State and Federal Laws and applicable regulations, as well as manufacturer's instructions when transporting, storing, handling, and using explosives. The appropriate manufacturer should be consulted in any situation when a blaster has any doubts or questions involving explosives.

This page intentionally left blank.

# **SECTION 1**

## **DUTIES AND RESPONSIBILITIES OF THE CERTIFIED BLASTER**

This page intentionally left blank.

## **SECTION 1 -- DUTIES AND RESPONSIBILITIES OF THE CERTIFIED BLASTER**

- Regulatory Responsibilities
- Responsible person in-charge
- Activities conducted safely
- Experienced Person
- Task Training
- Design and Loading (flyrock/dangerous effects)
- Reviewing Detailed Drill/Borehole Logs
- Pre-Inspection
- Hazard Alert
- Clearing of Blast Site
- Weather Monitoring
- Loading Procedures
- Weather Monitoring
- Clearing of Blast Area
- Blasting Signals
- Firing of Shot
- Reporting Requirements
- Post-Blast Examination
- Disposal of Misfires
- Blast Reports/Shot Record
- Inventory Log
- Report Theft or Loss of Explosives

## **DUTIES AND RESPONSIBILITIES OF THE CERTIFIED BLASTER**

Virginia Mineral Mine Safety Laws and Safety and Health Regulations for Mineral Mining require certain tasks to be performed by an individual certified as a Surface Blaster. Following is a list of the most critical duties and responsibilities of the certified surface blaster, with direct reference to the applicable section of the law or regulations.

1. A certified blaster shall be in direct charge of blasting activities. (4 VAC 25-40-800.A.)
2. Ensure that all activities under their supervision are conducted in a safe manner (45.1-161.292:6 (B) & 4 VAC 25-40-190)
  - (a) Blasting crew has appropriate personal protective equipment. (4 VAC 25-40-1710/20/20/40)
  - (b) Blasting crew not under influence of drugs/alcohol. (4 VAC 25-40-250)
  - (c) Finger rings prohibited. (4 VAC 25-40-1780)
  - (d) Prevent smoking within 50 feet of explosives or detonators. (4 VAC 25-40-800.F.)
3. Ensure that all miners with less than six months experience work with, or under the supervision of, an experienced person. (4 VAC 25-40-110)
4. Provide task training for all new, or reassigned, employees involved in blasting activities. (4 VAC 25-40-100)
5. Design and load the shot to prevent flyrock or other dangerous effects (ex: air overpressure, ground vibration, ground control). Report flyrock incidents immediately to DMM and note the details on the blast record. (4 VAC 25-40-800.D.)
6. Inspect the blast site for hazards. (4 VAC 25-40-800.G.2.)
7. Alert blasting crew to hazards involved: (4 VAC 25-40-800.B.)
8. Ensure that the blast site is cleared of all nonessential personnel and equipment prior to bringing explosives to the site. (4 VAC 25-40-800.G.4.)
9. Monitor weather conditions to ensure safe loading & firing. (4 VAC 25-40-800.G.1.)
10. Ensure proper loading procedures are followed: (4 VAC 25-40-800.H. through K.)
  - (a) Review the drill logs for each borehole to determine specific downhole conditions prior to loading the shot. (4 VAC 25-40-800.H.)
  - (b) Load boreholes as near to the blasting time as possible. (4 VAC 25-40-800.I.)

- (c) Blast as soon as possible upon completion of loading. (4 VAC 25-40-800.I.)
  - (d) Keep explosives & detonators a safe distance from each other until made into a primer. (4 VAC 25-40-800.J.)
  - (e) Ensure primers are not made up or assembled in advance. (4 VAC 25-40-800.K.)
  - (f) Make sure detonators are inserted completely and securely into explosive cartridges used as primers and that priming is sufficient to detonate the explosive column in the borehole. (4 VAC 25-40-800.M.)
  - (g) Ensure that primers are inserted into the borehole slowly to prevent accidental detonation from impact, and that tamping is not done directly on the primer. (4 VAC 25-40-800.N.)
11. Remove all personnel/miners from the blast area prior to connection of the detonation device. (4 VAC 25-40-800.S.)
  12. Ensure blasting signals (audible warning signal) are given & posted. (4 VAC 25-40-800.R.)
  13. Fire the shot from a safe location. (4VAC 25-40-800.T.)
  14. Report to the operator (who must report to DMM) any unplanned explosion, serious fire, serious or fatal injury, or any occurrence of flyrock. (45.1-161.292:51 & 52; 4 VAC 25-40-800.D.)
  15. Perform a post-blast examination of the blast area, and ensure that the all clear signal is given prior to miners returning to work in the area. (4 VAC 25-40-800.U.)
  16. Properly dispose of all misfires after waiting 15 minutes. Guard or barricade & post warning signs until corrected. (4 VAC 25-40-820.A., B., & C.)
  17. Complete a detailed blast record for all blasts and maintain the records on-site for at least 3 years. (4 VAC 25-40-810)
  18. Keep on-site an accurate inventory log of all explosives and detonators stored at the mine. (4 VAC 25-40-780.D.)
  19. Ensure that any theft or unaccounted loss of explosives is reported to the local police, the State Police, U.S. Department of Justice, Bureau of Alcohol, Tobacco, Firearms, and Explosives, and the Division of Mineral Mining. (4 VAC 25-40-780.E.)

\*In addition to the items listed above, some mining operations have blasting requirements set by a local government jurisdictional authority that the blaster must follow.

This page intentionally left blank.

## **SECTION 2**

### **HAZARD RECOGNITION IN BLASTING**

This page intentionally left blank.

## **SECTION 2 – HAZARD RECOGNITION IN BLASTING**

- Introduction
  - Rock Structure
  - Types of Minerals in Virginia
  - Natural Geologic Hazards
  
- Misfires
  - Introduction
  - Prevention of Misfires
  - Handling of Misfires
  - Regulations Related to Misfires
  
- Wet Holes
  
- Extraneous Electricity
  - Definitions
  - Sources of Extraneous Electricity
  - Background (minimum firing current)
  - Minimizing the Probability of Stray Current

# HAZARD RECOGNITION IN BLASTING

## Introduction

The certified blaster needs to be able to recognize safety hazards that are natural to the geological formation he is working with as well as safety hazards that can be created by blasting. Weather, in the form of rain, freezing temperatures, and thawing can also create hazards. Rock mass has a wide variety in geology and structure. Rock characteristics can vary greatly from one part of a mine to another. Bedding planes, joints, cracks, faults, open beds, cavities, mud seams, and zones of weakness/incompetent rock may be detected by a driller and aid the certified blaster in avoiding or creating a hazard. An accurate, detailed drilling log (required by 4 VAC 25-40-1095) and good communications between the certified blaster and driller can help in maintaining a successful blasting program.

## Rock Structure

Rock structure can be described as the features produced in a rock by movements during and after its formation. Rock structure is the result of what has happened to rock over millions, even billions of years.

## Classification/Types of Minerals Mined in Virginia

Classifications:

- Sedimentary Rock – a layered rock, formed through the accumulation and solidification of sediment, which may originally be made up of minerals, rock debris, animal or vegetable matter.

Examples: Limestone, Sandstone, shale, gypsum, conglomerate, salt

- Igneous Rock – formed from molten material that solidified upon cooling.

Examples: Granite

- Metamorphic Rock – formed (while in the solid state) by the transformation of pre-existing rock beneath the earth's surface through agencies of heat, pressure, and chemical active fluids.

Examples: Slate (was shale), quartzite (was sandstone), marble (was limestone)

## Natural Geologic/Ground Control Hazards

Natural geologic/ground control hazards are defined as a condition in the rock or mineral deposit that may pose a safety or health threat to personnel. This can result from mining activity or from natural geology of the formation.

Faults – fractures with subsequent rock movement along one or both sides of the fracture zone. A fault may contain fine-grained material or recrystallized rock. During blasting, faults can cause overbreak or backbreak to a fault plane. Venting or blowout could occur if material within the fault zone is weakly cemented/formed.

Bedding – the layering or planes dividing rock formations. Separation of beds can be fractions of an inch to tens of feet apart.

Joints – cracks or fractures in rock with no associated displacement. A joint can be intersecting with as well as perpendicular or parallel to bedding planes. It is common for a complex pattern of many joints to be present in a single geologic unit. Joints are usually most troubling relative to distributing and confining explosive energy within a rock mass, especially if existing joints are open.

Contacts – places or surfaces where different rock types come together.

Hazards that can result from mining activity include overhanging material, loose unconsolidated material on the face, back-break, excess toe, oversize rock, and airborne contamination/exposure of harmful substances (silica, asbestos).

For most mineral mines, maximum dust exposure limits are determined by the amount of free silica (quartz) found in airborne dust in their work environment. The percentage of quartz varies with the type of rock, sand, or mineral being mined. Granite tends to have a moderate to high percentage of silica while limestone is normally low; therefore a miner working at a limestone quarry has a much higher permissible exposure limit (PEL) for dust than a miner working at a granite quarry.

Miners who inhale tiny (respirable) particles of silica run the risk of contracting “silicosis” which can seriously impair their ability to breathe normally. Any type of dust, fume or mist inhaled can be detrimental; therefore, miners should minimize their exposure by ensuring that control measures such as water sprays and dust collectors are operational, and by using appropriate PPE supplied by the mine operator.

Hazards that can result from geological conditions include fault zones, slip planes, bedding, caves/cavities, fracture formations, mud/dirt seams, weathering, aquifers, joints/folds.

An examination for unsafe conditions, and the responsibility to report such conditions, is the direct responsibility of each miner (4 VAC 25-40-460).

# Misfires

## Introduction

The certified blaster's search for misfired explosives after the shot must be thorough since every charge that does not detonate truly represents a potential accident.

**The rule in blasting is, or should be, that the best way to handle a misfire is to prevent it from occurring in the first place.**

## Prevention of Misfires

The best way to prevent a misfire is to become familiar with the most common causes. Twelve of the most common causes are listed below:

1. Poor wire/tubing connections (corrosion, dirt)
2. Bare splices on the ground, lying in water or wet areas
3. Improper detonator circuit
4. Improperly balanced detonator circuit
5. Current leakage or damaged tubing
6. Mixing detonators from different manufacturers in the same blast
7. Detonators not wired or connected into the circuit
8. Defective or inadequate firing line
9. Inadequate power supply
10. Improperly made primers
11. Using nonwater resistant explosives in wet holes
12. Improper loading practices

Occasionally, a primer will detonate but not initiate a portion of the powder column. These misfires are often due to ground movement cutoffs, inadequate priming, deteriorated explosives, or bridged charges in the borehole.

## Handling of Misfires

Under most conditions the safest way to dispose of a misfire is to reshoot it, provided there is sufficient burden around the borehole to prevent flyrock hazards. If electric detonators fail or if nonelectric initiators fail, an attempt to shoot the borehole with a fresh primer may be made if deemed safe by the certified blaster in charge.

This work will require the stemming to be removed; such work must be done with great care. The best method to remove stemming is with a stream of water through a plastic pipe or hose. Once the stemming is removed a new primer may be inserted in the borehole. There have been cases where the second primer did not initiate the entire powder column but generated enough heat to cause the original misfired charges to start burning. This will result in a

dangerous “hang fire” which may detonate several minutes later. The sound of a reprimed charge is not a certain indication that the original misfire has completely detonated.

### **Regulations Related to Misfires**

4 VAC 25-40-820 -- provides for a 15 minute waiting time before entering the blast area; disposal to be done in a safe manner by the certified blaster; and the guarding or barricading and posting of warning signs until the misfire is cleared.

4 VAC 25-40-800.A. -- a certified blaster shall be in direct charge of blasting activities.

### **Wet Holes**

Boreholes that contain moisture should not be loaded with unprotected ANFO. A water-resistant ANFO product should be used. Water readily dissolves ammonium nitrate prills, leading to desensitization of the ANFO. This desensitizing effect of water has been demonstrated in many poor blasts where ANFO was used in wet boreholes without sufficient emulsion or external protection.

Wet hole bags can easily become separated by floating in water or mud in the borehole. Frequent priming of every other bag can help overcome the substandard performance from this problem.

In severe water conditions, a water-resistant product should be loaded as packaged and shot as soon as possible. Certified blasters must know their water conditions and use products that will perform safely.

In addition to wet hole explosive bags, other measures used to combat water problems are borehole liners & dewatering.

### **Extraneous Electricity**

#### **Definitions**

Stray Current – current that flows outside an insulated conductor system.

Static Electricity – electrical energy that is stored at rest on some person or object.

#### **Sources of Extraneous Electricity**

1. Lightning discharges to ground from electrical storms.
2. Stray ground currents from poorly insulated and improperly grounded electrical equipment.
3. Radio frequency (RF) energy from transmitters.
4. Induced currents, present in electromagnetic fields, such as those commonly found near high-voltage transmission lines.

5. Static electricity generated by wind-driven dust and snowstorms, by moving conveyor belts, and by the pneumatic conveying of ANFO.
6. Galvanic currents generated by dissimilar metals touching or separated by a conductive material.

Static electricity can be generated in the atmosphere and stored on any insulated and ungrounded conductive body, such as a person or truck and can be discharged through detonator wires.

Intense high-frequency radiation can accidentally initiate electric detonators. Therefore, an investigation of any potentially hazardous source of radio frequency (RF) energy near a blasting site should be conducted when using electric detonators. The Institute of Makers of Explosives (IME) Safety Library Publication #20 classifies sources of radio frequency and lists safe distances.

Other sources of possible stray current include electric fences in the blast area, metal fences, machinery housings, conductive rock strata, and any other object in contact with a defective insulated electrical source.

**Lightning** undoubtedly represents the greatest single hazard to blasting because of its erratic nature and high energy whether using an electric, electronic, or nonelectric system. **In the interest of safety, blasting should be suspended, and all personnel should be evacuated to a safe distance from the blast area whenever lightning storms are in the vicinity.** The danger from lightning is considerably increased if there is a transmission line, water line, compressed air line, fence, stream, or other conductor available to carry the current between the storm and the shot location. A common sense rule is to evacuate the shot area when thunderstorm activity comes within 5 miles of the shot site.

## **Background**

The minimum firing current for commercial electric blasting caps presently manufactured in the United States is approximately **0.25 amperes** (250 milliamperes). The IME has established the maximum “safe” current permitted to flow through an electric blasting cap without hazard of detonation as 0.05 amperes (50 milliamperes).

When extraneous currents such as stray current exceeds .05 amps, the source of current must be traced and eliminated before electric-blasting caps can be used safely. **If the source of current cannot be traced and eliminated, then a nonelectric system of initiation must be used.**

## **Safety Procedures to Help Minimize the Probability of Stray Current**

1. If an electrical power distribution system and/or electrically operated equipment is located near a blasting site, then periodic checks of the wire and insulation should be made to ensure it is maintained in good condition.

2. All metal objects, pipes, framework of metal housings, etc., should be provided with a low resistance ground to earth.
3. Remove all possible potential sources of stray current such as powerlines, lights, electric equipment, batteries, etc. from the blast site prior to the loading of explosives.
4. Known stray current sources located near blasting should be de-energized and locked out when explosive materials are present.
5. Do not remove shunts from detonator legwires except for continuity testing, after which they should be re-shunted, and kept shunted until tying them into the blast circuit.
6. Ensure that all splices are insulated from the earth or ground and other potential stray current sources. Always use a well-insulated firing line that is not damaged and is not near any possible source of stray current.
7. Precautions to take during dust and snowstorms include placing the electric detonators on the ground and slowly extend the legwires along the ground.
8. Electric blasting should be suspended when severe dust or snowstorms are present.
9. All moving equipment in the blast site that can generate static electricity should be shut down while blasting circuits are being connected and until the blast has been fired.
10. A semi-conductive loading system for ANFO will help to bleed off the static charge as it is generated.
11. Make certain that there are no radio frequency transmitting devices (including cellular phones) closer than recommended by The Institute of Makers of Explosives (IME) and be on the lookout for new structures/antennas.
12. Keep mobile radio transmitters in the “off” position near blasting areas and place adequate signs to remind mobile transmitter operators.

This page intentionally left blank.

## **SECTION 3**

### **BASIC KNOWLEDGE OF BLASTING**

This page intentionally left blank.

## SECTION 3 – BASIC KNOWLEDGE OF BLASTING

- Explosive Properties – General
- Explosive Products
  - Dynamite
  - Water Gels/Slurries
  - Emulsions
  - Anfo – Blasting Prills
  - Blends
  - Boosters
  - Initiating Devices
    - Electric
    - Electronic
    - Non-electric
      - Detonating Cord
      - Shock Tube
  - Black Powder
- Blasting Instruments
  - Blaster's Multimeter
  - Blaster's Ohmmeter
  - Blasting Machines
  - Seismograph

# **BASIC KNOWLEDGE OF BLASTING**

## **Explosive Properties**

An explosive is a chemical compound, or mixture of compounds, initiated by heat, shock, impact, friction, or a combination of these conditions. Once initiated, it decomposes very rapidly in a detonation producing a rapid release of heat and large quantities of high-pressure gases. The gases produced expand rapidly with sufficient force to overcome confining forces, such as the rock surrounding a borehole. High explosives are categorized as being able to be initiated by a No. 8 test blasting cap, and which react at a speed greater than the speed of sound through the explosive medium.

If improperly or accidentally initiated, explosives may burn without the aid of atmospheric oxygen. The flame burning of explosives is called deflagration.

The energy released by the detonation of explosives manifests itself in four basic ways: 1) rock fragmentation; 2) rock displacement; 3) ground vibration; and 4) airblast. In addition, toxic and non-toxic fumes are also produced, and are released into the atmosphere.

All explosives have specific characteristics which differentiate them, and which can be measured to determine their performance under specific blasting conditions. A brief explanation of some of the more important explosive properties follows.

### **Detonation Velocity**

Detonation velocity (DV) is the speed at which the detonation wave travels through a column of explosives. DV is typically measured in feet per second (fps), or meters per second (m/s), and may be affected by many factors including explosive type, diameter of the explosive column, confinement, and temperature. Most commercially available explosives in use today have detonation velocities in the range of 10,000-18,000-fps. Each explosive has an ideal velocity, which is dependent on the explosive's composition and density.

Depending on the type of explosive, and how it is confined, the diameter of the product will influence the DV up to a certain charge diameter. Generally, the larger the diameter the greater the velocity until the explosive's maximum (ideal) velocity is reached. DV is also strongly dependent on the density (packing density in a drill hole) of the explosive. All explosives also have a critical diameter, which is the smallest charge diameter at which the detonation process will support itself once initiated.

Confinement of the explosive charge will also affect the DV. Generally, the greater the confinement of the explosive, the higher the DV. For some explosive products such as ANFO, dynamites, emulsions, heavy ANFO, and water gels the effect of confinement can be significant in small diameter holes. Confinement usually has less influence on DV as the charge diameter increases.

Adequate priming of an explosive charge is critical in ensuring that the detonation will reach its maximum velocity as quickly as possible. If priming is inadequate the charge may fail to detonate, may build up slowly to its final velocity, or may initiate a low order detonation or deflagration. Blasters should always follow the explosive manufacturer's recommendations for priming in order to ensure maximum velocities.

## **Density**

The packing density of an explosive loaded in a borehole is one of its most critical properties. Density affects sensitivity, DV, and critical diameter of the explosive charge. It is defined as the weight per unit volume and is typically expressed in grams per cubic centimeter (g/cc). The density of most commercial explosives ranges from a low of about 0.8 g/cc to a high of about 1.6 g/cc. Free-flowing ANFO products are in the low density range of approximately 0.8 - 1.15 g/cc. Cartridge explosive products such as emulsions, water gels, and dynamites have densities in the range of 0.9 -1.6 g/cc. Since water is considered to have a density of 1.0 any product with a density of less than 1.0 will float. Blasters should also realize that muddy water or salt water in a borehole might have a density greater than 1.0 g/cc.

## **Sensitivity**

Sensitivity is a loosely used term that indicates the absolute or relative ease with which an explosive can be induced to chemically react. Different explosives will show differing sensitivity to stimuli such as shock, low velocity impact, friction, electrostatic discharge, or other sources of energy. The shock initiation sensitivity is the ease with which an explosive can be induced to detonate. Some explosives require only a single detonator for initiation, while others require large booster charges.

Detonator, or cap sensitivity, is one measure commonly used to indicate product ease of initiation, and also to classify products for safety in transportation, storage, and use. The standard used is the explosives' sensitivity to initiation by a No. 8 test blasting cap. Blasting agents are an example of an explosive product that will not initiate with the detonation of the No. 8 test cap, under test conditions.

## **Fumes**

The chemical reaction resulting from the detonation of explosives produces water vapor, carbon dioxide, and nitrogen, and also, in smaller concentrations, poisonous gases such as carbon monoxide and nitrogen oxides. Fumes differ from smoke, in that smoke is mostly steam and the solid products of combustion and detonation. Exposure to smoke, especially that produced from dynamite, should be avoided as severe headaches may result from contact with small particles of unreacted nitroglycerin in the smoke. Some carbon monoxide and oxides of nitrogen will be produced from all detonations, with the amounts depending on the conditions of the detonation. It is imperative that adequate waiting periods be observed before allowing personnel to enter the blast area, as some toxic gases are both odorless and colorless. Absence of smoke is no guarantee that noxious gases are not present in the blast area; therefore, always ensure the area has been sufficiently ventilated before entering.

## Flammability

Flammability refers to the ease with which an explosive or blasting agent can be ignited by heat. As you might suspect, most dynamites are easy to ignite and burn violently. If the burning takes place in a confined space the burning may transform into a detonation. Water gels and emulsions are more difficult to ignite than dynamite; however, after most of their water is evaporated by a heat source they can support combustion without confinement. Of the most common commercial explosives, ammonium nitrate products, emulsions and water gels have a lower tendency than dynamite to convert burning into a detonation.

## Explosive Classification

The U.S. Dept. of Transportation (DOT) uses the United Nations explosives shipping classification system. This system is based on hazard in shipping only, versus the previous DOT system that considered both shipping and use hazards.

*Division 1.1 explosives (with a mass explosion hazard):* This class exhibits the maximum hazard potential and will affect the entire load almost instantaneously. Examples include such products as dynamite, black powder, certain watergels/slurries, certain blasting caps, electric and non-electric detonators, detonating cord, MS connectors, primers, boosters, etc. Other examples include shaped charges, grenades, mines, and nitroglycerin desensitized.

*Division 1.2 explosives (with a projection hazard):* This class exhibits a projection hazard but not a mass explosive hazard. Examples include rocket propellants, certain fireworks, aerial and surface flares.

*Division 1.3 explosives (with predominantly a fire hazard):* This class possesses a flammable hazard, and includes smokeless powder, fireworks (display), tracers for ammunition, projectiles.

*Division 1.4 (minor explosion hazard):* This class exhibits a minor explosion hazard with the explosive effects this material largely confined to the package and no projection of fragments of any appreciable size or range expected. Examples include some types of blasting caps and detonating cord, consumer fireworks, small arms ammunition.

*Division 1.5 (very insensitive explosives):* This class has a mass explosive hazard, but it is represented by a low probability of transition from burning to detonation while in normal transportation. Examples include primarily blasting agents, such as ANFO, and low sensitivity water gels.

*Division 1.6 (extremely insensitive explosives, no mass explosions):* This class contains only extremely insensitive detonating substances that demonstrate a negligible probability of accident initiation or propagation.

## Explosive Products

### Dynamite

Dynamite has been a mainstay of the commercial explosives industry, ever since Alfred Nobel learned that nitroglycerin absorbed into diatomaceous earth was safer to transport, and use. Most modern dynamites contain nitroglycerin as a sensitizer, or as the principal means for developing energy. Where field conditions permit, ANFO, water gels, and emulsions have replaced dynamite as lower cost alternatives. Dynamites are packed into cylindrical cartridges  $\frac{3}{4}$ -inch diameter or larger, and ranging from 4 inches to 24 inches in length.

The three basic types of dynamite are: granular, semi-gelatin, and gelatin. The semi-gelatin and gelatin dynamites contain nitrocellulose, a cellulose nitrate that combines with nitroglycerin to form a cohesive gel, in relatively high percentages. Dynamites also differ in the principal materials used to provide their energy. In 'straight' dynamites nitroglycerin is the principal energy source, in 'ammonia', or so-called 'extra', dynamites ammonium nitrate replaces a large portion of the nitroglycerin to create less expensive and more impact resistant dynamite. In these dynamites the ammonium nitrate is the principal source of energy, and the nitroglycerin acts as a sensitizer.

The nitroglycerin in dynamite can be inhaled, or absorbed through the skin. It acts as a blood vessel dilator, reducing the amount of blood flow to the brain, and causing headaches that are sometimes severe.

### Water Gels and Slurries

“A water gel/slurry explosive is essentially a thickened aqueous solution of oxidizer and/or fuel salts in which is dispersed additional oxidizers and/or fuels as well as sensitizers.”<sup>4</sup> As a slurry the explosive is fluid, pumpable and essentially miscible with water. As a water gel formulation the explosive has been made dimensionally stable and water-resistant by the addition of cross-linking agents. Water gel explosives contain significant amounts of water and separate oxidizer and fuel components making them less sensitive than water-free nitroglycerin dynamites. Water gels are made up of oxidizing salts and fuels dispersed in a continuous liquid phase. The addition of gellants, and cross-linking agents, thickens the mixture and makes it water-resistant. Ammonium nitrate, sodium nitrate, and calcium nitrate are the oxidizing salts most commonly used, whereas aluminum, coal, gilsonite, sugar, ethylene glycol, and oil are the most common fuels. The addition of nitrate salts of organic amines, nitrate esters of alcohol, perchlorate salts, fine particle size aluminum, or other explosives may adjust the sensitiveness of the water gels. Also, physical sensitizers such as chemically produced bubbles, or glass 'microballoons', may be blended into the gel either alone, or in combination with other chemical sensitizers. The density of most water gels ranges from 1.0 – 1.35 g/cc. Water gels may be formulated to be either cap sensitive, or insensitive. In either case they are less sensitive to abusive impact, shock, or fire than dynamite. They are explosives, however, and should never be abused. The sensitivity of water gels is affected by temperature, with higher temperatures increasing the sensitivity of the products.

<sup>4</sup> ISEE Blaster's Handbook, 17<sup>th</sup> Edition, Chapter 6, Water Gels/Slurries, pg. 69.

## **Emulsions**

Emulsion explosives are the combination of two immiscible (incapable of mixing) liquids in which one phase is uniformly dispersed throughout the other. They are dispersions of water solutions of oxidizers in an oil medium, or water-in-oil emulsions. The unique structure provides a high ratio of oxidizer to fuel, and gives the emulsion its unique characteristics. The fuel phase of an emulsion is typically oil or wax, or a combination of the two. No. 2 fuel oil is common to many emulsions. The oxidizer solution phase consists of microscopically fine droplets that are surrounded by the fuel phase. The oxidizer solution always contains ammonium nitrate, and may also contain sodium nitrate, calcium nitrate, and ammonium or sodium perchlorate. The oxidizer remains dispersed in the fuel to form a stable emulsion through the addition of a surfactant or emulsifying agent. The ratio of oxidizer to fuel in an emulsion is typically 9:1. In some cases aluminum, or ANFO, is added to an emulsion to increase the energy of the explosive. Emulsions have been found to be very safe explosives to handle, and use, and have failed to detonate in impact and friction tests standard to the industry. Emulsions will normally not detonate during burning, but there is no guarantee of this, especially if the emulsion has become contaminated with other materials. Although emulsions express a great degree of safety they will detonate if exposed to severe conditions, and should never be abused. Emulsions may be formulated as cap sensitive or insensitive explosives.

## **ANFO – Blasting Prills**

Ammonium nitrate is an essential ingredient in nearly all commercial explosives including those mentioned above. Predominantly it is used in the form of a small porous pellet called a prill, and mixed with fuel oil. Approximately four billion pounds of ANFO (ammonium nitrate-fuel oil) is consumed in the U.S. annually accounting for nearly 80% of the domestic commercial explosives market. The main limitations of ANFO are no water resistance, and low product density. ANFO in its most commonly used formulation consists of 94% ammonium nitrate prills, and 6% No. 2 diesel fuel. Although ammonium nitrate prills are extensively used as agricultural fertilizers they differ from explosive grade prills, as they are denser and less porous. The detonation velocity of ANFO is largely dependent on the size of the borehole and degree of confinement. DV may reach nearly 16,000 fps under optimum conditions. Most ANFO has a poured density of 0.77 to 0.85 g/cc with a practical maximum density of about 1.10 g/cc. ANFO is not cap sensitive, and must be primed to achieve maximum DV. When priming ANFO, the highest detonation pressure material available should be used thus assuring the ANFO reaches its steady state velocity within a minimum distance from the point of initiation. Efficient primers for ANFO have diameters that approach the diameter of the borehole, especially in holes less than five inches in size. ANFO has no water resistance, and therefore should never be loaded unprotected into boreholes containing water. ANFO may be loaded bulk, may be packaged in bags, or may be packaged for loading in cylindrical textile, or cardboard, tubes with plastic liners.

## **Blends**

Generally, a blend is a mixture of a water-in-oil emulsion and ANFO. They are typically not sensitive to initiation by means of a blasting cap, and are classified as blasting agents. There are three main purposes for blends. They are: 1) to increase the density of ANFO, thereby

increasing energy in the borehole; 2) to provide water resistance to ANFO; and 3) to reduce mining costs. Blends containing less than 50% emulsion are sometimes called 'heavy ANFO'. Some formulations of blends may reach detonation velocities in excess of 18,000 fps. Blending of the products allows a wide range of detonation velocities, and densities for the explosive user. Once the mixture reaches a ratio of 40:60 (emulsion:ANFO) the mixture is essentially waterproof. At a ratio of 60:40, the mixture may be pumped.

### **Boosters/Primers**

A booster is an explosive used to perpetuate or intensify an explosive reaction. A booster is often, but not always, cap sensitive and does not contain an initiating device. The terms primer and booster are often used interchangeably, but the two serve very different functions. A primer is used to initiate an explosive reaction, and contains a detonator, detonating cord, etc., whereas a booster does not contain a detonator. Dynamite, water gel/slurries, and emulsions are all sometimes used as boosters for ANFO products. Many cast boosters are also used as primers, and are molded with a cap well in the booster so that insertion of a detonator is made easier. Other types of cap sensitive explosives may also be used to make primers.

The popularity of ANFO and water gels created the need for the development of high-velocity and high-energy boosters. Compact, high detonation pressure, non-nitroglycerin boosters have been developed to meet this need. Even though these boosters are more resistant to accidental detonation from impact, shock, or friction than dynamite they must be handled safely.

Cast boosters are cap sensitive explosives that typically contain the high explosive trinitrotoluene (TNT) as the casting material. Other explosive materials may be mixed into the melted TNT, and will impart different energy and/or sensitivity to the booster. Some types of cast boosters are pentolite boosters, composition B boosters, torpex boosters, and amatol/sodatol boosters. The density of cast boosters ranges from 1.55-1.7 g/cc, and they have excellent water resistance. They detonate at velocities of 20,000-25,000 fps, or more.

In addition to the cast boosters, nitroglycerin explosive boosters are still commonly used. These are usually found in stick, or cylindrical form. Ammonium nitrate gelatins (so-called 'extra' gelatins) are the most popular of this type.

An accepted rule-of-thumb for efficient priming is to use the largest diameter primer that will fit the borehole. The primer is usually located at, or near, the bottom of the borehole. Bottom initiation serves to maximize confinement of the charge, and tends to produce less flyrock and airblast than top initiated holes. Multiple primers may be used in single boreholes to ensure detonation of the entire explosive column, and to initiate separate, decked, explosive charges. Primers should never be made up until immediately prior to insertion into the borehole, and primer components should be kept physically separated until that time. When cartridge explosives are used as primers it may be necessary to make a hole in the explosive in order to seat the detonator. Only non-sparking implements (i.e. powder punch) should be used for this purpose. The detonator should always be completely seated within the explosive

cartridge. Since detonators fire directionally they should be oriented toward the center of the cartridge (see Diagram 3-1 for examples of primers).

## Initiating Devices

Only by the careful choice, and utilization, of the proper initiating device can blasters achieve the most effective use of explosives. Blasters must always remember that all initiating devices are designed to explode, and must be handled with the same care as high explosives. Depending on the prime source of energy, initiating devices fall into three basic types: electric, electronic, and non-electric. Blasting caps may be instantaneous, or delayed in milliseconds ( $1/1000^{\text{th}}$  of a second). To constitute separate detonations a delay must be at least 8 ms (milliseconds), however, most detonators are delayed in intervals of 25 ms.

## Electric Detonators

Electric detonator systems have been in use in the mining industry for many decades. Electric detonators come in several types with the most common being the low firing –current variety. An electric detonator consists of two leg wires embedded in a metal shell containing a high explosive base charge that is designed to initiate other explosives. Above the base charge is a primary charge designed to convert the burning reaction transmitted from the ignition source into a detonation. Above the primary charge, in delay detonators, is a pyrotechnic charge, which burns at a known rate. At the top of the detonator is the bridge wire that receives the electric current from the leg wires, which protrude from the cap. The bridge wire is encased in an ignition mixture. Internal safeguards are built into all modern commercial detonators in order to prevent electrostatic energy from accidentally initiating the detonator. Electric detonators, which contain no pyrotechnic delay charge, are considered instantaneous detonators. The burning time of any delay charge determines the millisecond delay period of the cap.

### Diagram 3-1. Primers

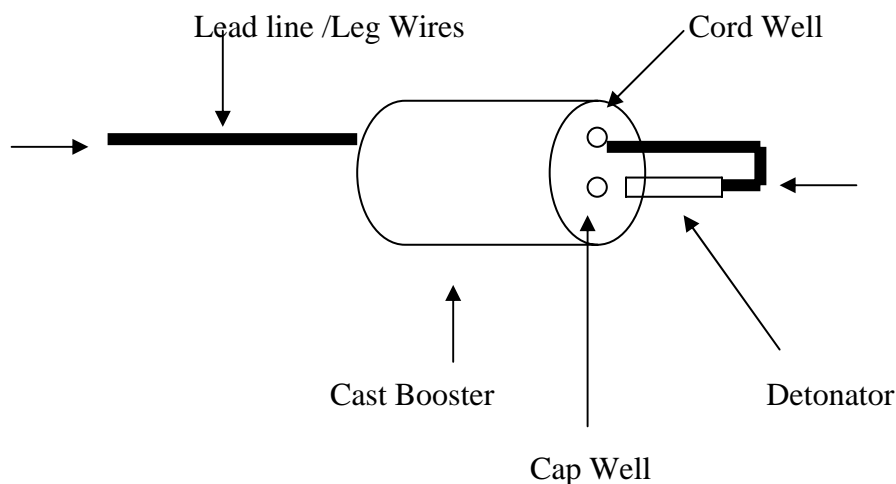

Detonator leg wires may be made of copper, iron, or copper clad iron and come in a variety of gauges and lengths. Electric detonators produced in North America have shunts on the free ends of the leg wires to prevent current from unintentionally flowing through the bridge wire.

Internal construction of electric detonators varies with different manufacturers, therefore, electric detonators from different manufacturers must never be used in the same blast. Such a practice is almost certain to result in dangerous misfires.

In a cast booster the lead lines/leg wires are fed through the booster, and the detonator is then inserted into the cap well so that the detonation is directed into the explosive.

When making a primer using slurry or cartridge explosives, it may be necessary to make a hole in the explosive cartridge with a non-sparking implement. The lead line/leg wires may then be half-hitched around the cartridge, or taped to the cartridge. The detonator must be seated completely within the explosive.

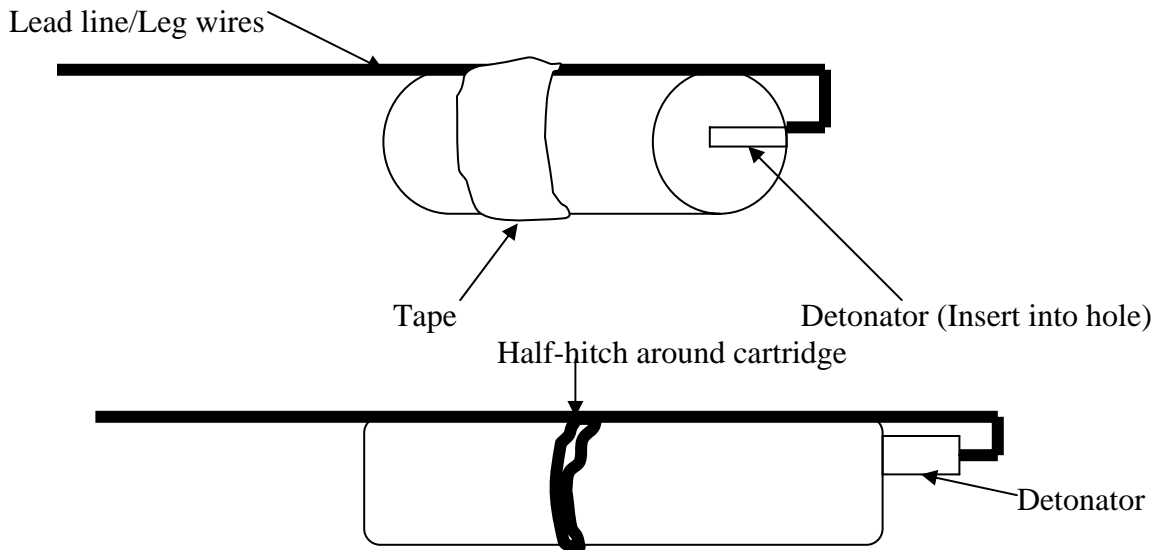

Proper electric blasting will allow for the safe firing of large numbers of detonators from a safe, remote location. “Successful electric blasting depends on four basic principles: 1) proper selection and layout of the blasting circuit; 2) an adequate energy source compatible with the type of circuit selected; 3) recognition and elimination of all electrical hazards; and 4) circuit balancing, good electrical connections, and careful circuit testing.”<sup>5</sup> The type of circuit will depend to a great extent on the number of detonators to be fired, and the type of operation.

Generally, a single series is used on shots containing 50 detonators or less.<sup>5</sup> For delivering the electrical energy to the circuit a capacitor discharge blasting machine offers the safest, most dependable, and economical source.

Prior to loading any electrically detonated blast all electrical hazards must be eliminated. Such hazards are lightning, stray current, radio frequency energy from transmitters, induced currents from high voltage power lines, and static electricity.

Once loading begins, the connections between leg wires, connecting wires, and lead lines must be tight, clean, and insulated from the ground. Also, the circuit resistance of all circuits should be calculated and tested. The resistance of each detonator should be tested prior

<sup>5</sup> ISEE Blaster’s Handbook, 17<sup>th</sup> Edition, Chapter 6, Electric Firing Techniques, pg. 179.

to loading of the explosive charge, and the ends of leg wires, connecting wires, and lead lines should be kept shunted.

When testing electric blasting circuits a Blaster's Multimeter or Blasting Ohmmeter (Blasting Galvanometer) must be used. Use of any other instrument may result in enough current to cause a partial or total detonation.

Two basic types of electric blasting circuits will be discussed in this guide: single series and series-in-parallel (See Diagram 3-2). A single series circuit provides a single path for the current through all the detonators. It is usually limited to small blasts containing 50 detonators, or less. A series-in-parallel circuit is the most common type of electrical blasting circuit. In this type of circuit the ends of two, or more, single series circuits are connected together, and are then connected to the firing line. The main advantage of the series-in-parallel hook-up is that a large number of detonators can be initiated without a large increase in voltage requirements.

In order to test a blasting circuit it is first necessary to calculate the theoretical circuit resistance. Methods of calculating the resistance of single series, and series-in-parallel, circuits is as follows:

**Single series** – The total resistance of a single series circuit is the number of detonators times the resistance of one detonator (See Table 3-1) plus the resistance of any connecting wire and firing line.

Circuit Resistance = (No. of detonators x resistance of one detonator) + resistance of connecting wire + resistance of firing line. The resistance of wire is calculated by taking the resistance of 1000 feet of the appropriate gauge wire from a chart (See Table 3-2), multiplying the figure by the total number feet of that gauge wire used in the circuit, and then dividing by 1000.

$$\text{Resistance of wire} = \frac{\text{total length of wire} \times \text{resistance of 1000' of wire}}{1000}$$

Resistance figures are calculated, and measured, in Ohms.

*Example:* Calculate the total circuit resistance of a single series containing 20 detonators, with a resistance of 2.1 ohms each, 200' of 16-gauge connecting wire, and 1000' of 14-gauge firing line.

$$\text{Cap resistance} = 20 \times 2.1 \text{ ohms} = 42 \text{ ohms}$$

$$\text{Connecting wire resistance} = \frac{200 \times 4.02}{1000} = 0.804 \text{ ohms}$$

$$\text{Firing line resistance} = \frac{1000 \times 2.53}{1000} = 2.53 \text{ ohms}$$

$$\begin{aligned} \text{Total circuit resistance} &= 42 \text{ (detonators)} + 0.8 \text{ (connecting wire)} + 2.53 \text{ (firing lines)} \\ &= 45.33 \text{ ohms} \end{aligned}$$

**Diagram 3-2. Wiring Configurations**

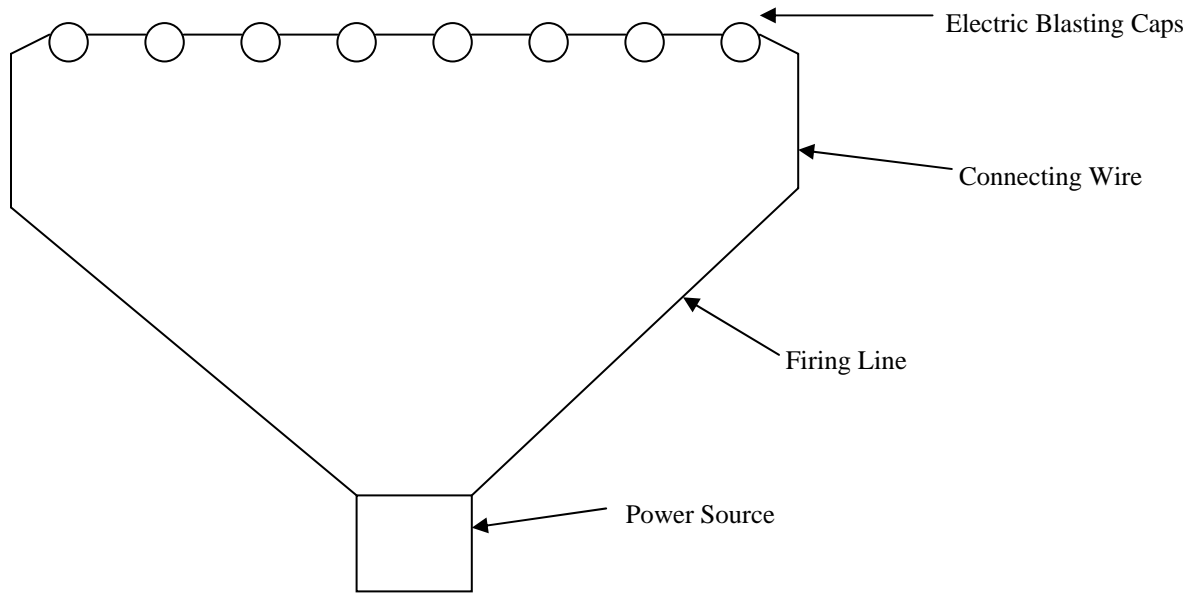

**A. Single Series Circuit**

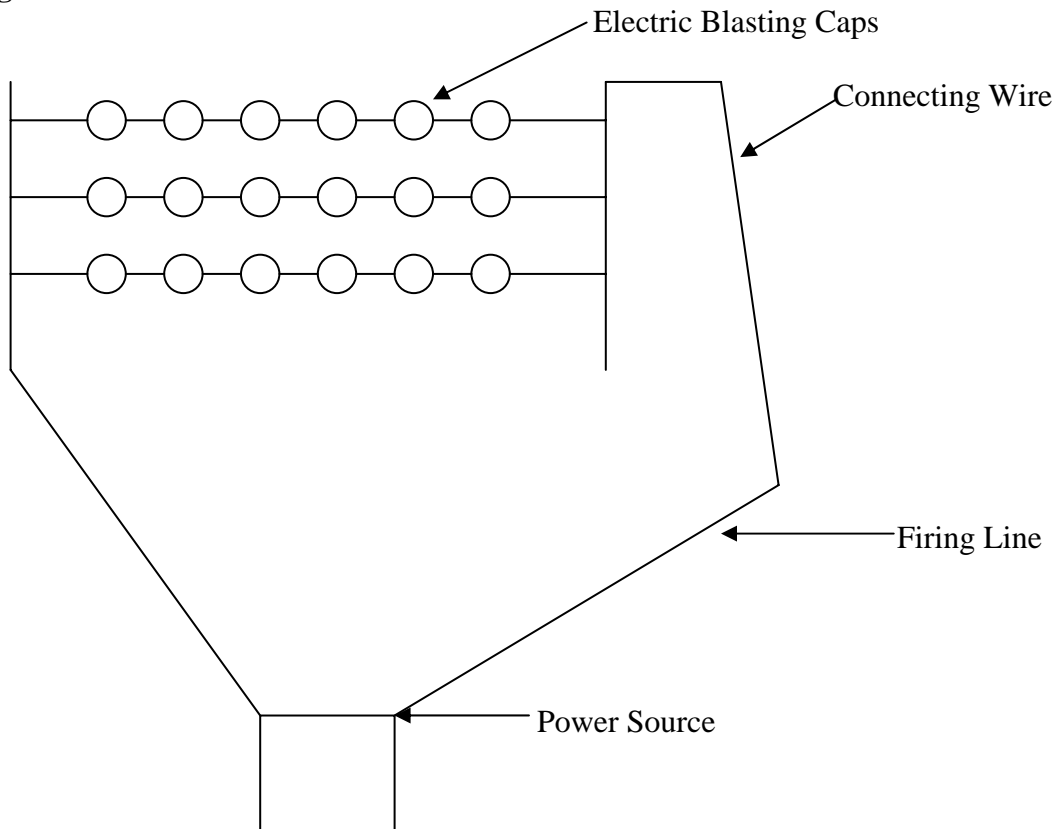

**B. Series-in-Parallel Circuit**

**Table 3-1.<sup>7</sup> Nominal Resistance\* of Electric Blasting Detonators in Ohms per Detonator**  
 (This is for sample calculations only: refer to your supplier for actual resistances of your products)

Length of Wire (Feet)	<u>Copper Wire</u>		<u>Iron Wire</u>	
	Instantaneous Detonators	Delay Detonators	Instantaneous Detonators	Delay Detonators
4	1.26	1.16	2.10	2.00
6	1.34	1.24	2.59	2.49
7	-	-	2.84	-
8	1.42	1.32	3.09	2.99
9	-	-	3.34	-
10	1.50	1.40	3.59	3.49
12	1.58	1.48	4.09	3.99
14	1.67	1.57	4.58	4.48
16	1.75	1.65	5.08	4.98
20	1.91	1.81	6.06	5.98
24	2.07	1.97		
30	2.15	2.21		
40	2.31	2.06		
50	2.42	2.32		
60	2.69	2.59		
80	2.71	2.61		
100	3.11	3.01		

\*At 68° Fahrenheit.

**Table 3-2.<sup>6</sup> Resistance\* of Copper Wire**

AWG Gauge No.	Ohms per 1,000 feet
6	0.395
8	0.628
10	0.999
12	1.588
14	2.525
16	4.02
18	6.39
20	10.15
22	16.14

\*At 68° Fahrenheit.

<sup>6</sup> ISEE Blaster's Handbook, 17<sup>th</sup> Edition, Chapter 16, Electric Firing Techniques, pg. 186.

<sup>7</sup> ISEE Blaster's Handbook, 17<sup>th</sup> Edition, Chapter 16, Electric Firing Techniques, pg. 185.

When tested the circuit should read between 45 and 46 ohms. If the reading is too low some detonators may not be connected in the circuit. If the reading is too high, it indicates that there are too many detonators in the series, or the connections are loose or dirty.

**Series-in-Parallel** – It is important to remember in series-in-parallel circuits that the resistance of all the series in the circuit should be balanced. Balancing the series is usually done by wiring the same number of detonators in each series. In order to determine the resistance of a balanced series-in-parallel circuit the resistance of one series, in the circuit, is divided by the total number of series in the circuit.

$$\text{Detonator circuit resistance} = \frac{\text{Resistance of one series}}{\text{Total number of series in the circuit}}$$

*Example:* Calculate the total resistance of a series-in-parallel circuit containing 5 series of 10 detonators each. The resistance of a single detonator is 2.32 ohms.

$$\begin{aligned} \text{Resistance of one series} &= 10(\text{detonators}) \times 2.32 \text{ ohms} \\ &= 23.2 \text{ ohms} \end{aligned}$$

Number of series in the circuit = 5

$$\begin{aligned} \text{Total resistance of the detonator circuit} &= \frac{23.2}{5} \\ &= 4.64 \text{ ohms} \end{aligned}$$

The resistance of the entire blasting circuit would be found in the same way as it was done in the previous example for a single series. The resistance of the detonator circuit would be added to the resistance of any connecting wire and the firing lines.

In order to find the current in any electrical circuit we can use Ohm's law. It states that the current flowing in a circuit is equal to the voltage divided by the resistance.

$$I = \frac{V}{R} \quad \text{Where: } I = \text{current in amperes}$$
$$V = \text{applied voltage in volts}$$
$$R = \text{resistance in ohms}$$

It is important to remember that the nominal/minimal firing current for each series, in a series-in-parallel hook-up, of blasting caps is 1.5-2.0 amperes depending on the manufacturer. If mixed series of instantaneous and delay detonators are used in a circuit, a current of 2.0 amperes should be used due to the fast functioning of the instantaneous caps.

Current leakage is another problem that can cause misfires when using electric detonators if it is undetected. Current leakage is the loss of a portion of the firing current through the ground, therefore bypassing the firing circuit. The leakage can be caused by the detonator leg wires being damaged during loading, the wire connections coming in contact with the ground, or improper splices in the boreholes. Current leakage can be detected by the use of a

Blaster's Multimeter or Blasting Galvanometer. The conductivity of the rock is the principal factor in the amount of current leakage that can occur.

Capacitor discharge blasting machines, when used properly, are the most dependable method of detonating electric blasting caps.

Capacitor discharge blasting machines are most commonly used for detonating electric blasts, but in order to determine if sufficient current is being delivered to the entire shot the blaster must consider the rapid current decay associated with the machine. Charts have been developed for use with individual blasting machines to show the number of detonators, and number of series, that the machine will safely detonate. Blasters must consult the appropriate chart for their machine to ensure it will deliver sufficient energy to detonate their planned blast.

The above information is provided for review only. It is not intended to be sufficient information to design a blast. Additional training, charts, and other information are required for each blast design. The information in this section is taken from the 17<sup>th</sup> edition of the ISEE Blaster's Handbook.

## **Electronic Detonators**

*(The information provided below is excerpted, in part, from MSHA Technical Support, Approval and Certification Center report PAR 0095053 A10 dated March 2008)*

Electronic detonator systems are new and continually advancing technology for the initiation of blasts in mining operations. Potential advantages for using electronic detonators are precise timing, reduced vibrations, a reduced sensitivity to stray electrical currents and radio frequencies, and a reduction in misfires through more precise circuit testing. Electronic blasting systems typically permit blasting with detonator delay times having millisecond or better accuracy.

Electronic detonators have been designed to eliminate the pyrotechnic fuse train that is a component of electric detonators, which improves timing accuracy and safety. For electronic detonators, typically an integrated circuit and a capacitor system internal to each detonator separate the leg wires from the base charge. Depending on the design features of the electronic detonator, the safety and timing accuracy can be greatly improved. The electronic detonator is a more complex design compared to a conventional electric detonator. A specially designed blast controller unique to each manufactured system transmits a selectable digital signal to each wired electronic detonator. The signal is identified by each electronic detonator and the detonation firing sequence is accurately assigned. The manufacturer's control unit will show any incomplete circuits during hookup prior to initiation of the explosive round. The wired round won't fire until all detonators in the circuit are properly accounted for with respect to the current blasting plan layout.

Using electronic detonators as designed and recommended by the manufacturer require specialized devices to identify, program and arm the blasting circuit. The detonators, connecting wires and accompanying items such as taggers, loggers, circuit testers and blast controllers are typically referred to as electronic blasting systems or electronic initiation

systems. Because of the unique design and construction of electronic blasting systems, each must be used according to the manufacturer's instructions.

Electronic initiation systems (electronic detonators) cannot be initiated by a conventional blasting unit, nor can it be activated without entering proper security codes. However, electronic detonators are still susceptible to initiation by lightning, fire, and impact of sufficient strength. Therefore, they must be properly transported, stored and handled as an explosive product.

Safety and Health Regulation 4 VAC 25-40-925 requires that electronic detonation systems be approved by the Division of Mineral Mining Director as providing performance equivalent to that required in 4 VAC 25-40-920 (electric detonators), and that they be used in accordance with the manufacturer's instructions.

There are currently 5 electronic blasting systems that are approved by DMM for use at Virginia mineral mine sites. These include:

- Austin E-Star System.
- Daveytronic Digital Blasting System.
- Orica I-KON Digital Energy Controlled System.
- Dyno Nobel Hot Shot & Digishot Systems.
- Orica Uni tronic Electronic Blasting System.

## **Non-electric Detonators**

There are two main types of non-electric detonation systems in use in North America today, shock tube and detonating cord. The main advantage of non-electric systems is perceived to be their lack of susceptibility to initiation from extraneous electrical energy. The shortcoming of most non-electric systems is that they cannot be tested to ensure a complete circuit exists prior to detonation.

First, we will discuss detonating cord systems. Detonating cord is a flexible cord containing a core of high explosives. The cord detonates at a velocity of approximately 22,000-fps. Different sizes of detonating cord are usually expressed as grains of explosive per linear foot of cord. The core of detonating cord is usually composed of PETN, and is covered with various combinations of materials. The cords are generally color coded by each manufacturer to identify the product grade. Detonating cord, although classified as a high explosive, is relatively insensitive, and requires close contact with at least a No. 6 detonator to assure initiation. Depending on the core load, and type of explosives, detonating cord **may** propagate through knots and splices. Most cords with at least 20 grains/ft of explosive will propagate through splices. The manufacturer's recommendations should be consulted, and followed, for each specific cord. When used down boreholes, exploding detonating cord will cause the compression of the explosive column surrounding the cord. This is a concern with explosives that have a critical density range in which they will detonate, such as ANFO in small diameter holes. Where compatible, detonating cord may also be used in conjunction with shock tube initiation systems.

One of the concerns with using detonating cord is the amount of noise generated when the cord explodes. Because of the noise, any cord greater than 3 grains/ft must be covered with at least 6 inches of loose earth when being used within 800 ft. of an inhabited building. Also, to insure complete detonation, a double trunk line or loop system must be used to connect holes in the blast. Other specific regulations for the use of non-electric detonating systems can be found in Sec. 4 VAC 25-40-930 of the Safety and Health Regulations for Mineral Mining.

Detonating cords with low core loads of 2.4-4.0 grains/ft are considered low energy cords. These cords transmit their explosive energy to an attached detonator. They are somewhat similar in appearance to shock tube systems, and are attractive in situations where it is important for the cord to self-destruct. By doing so, they leave no contamination in the product being mined.

Surface delay systems are available for both types of detonating cord, therefore, allowing flexibility in blast delay patterns. Detonating cord should always be cut with a knife, and not with pliers, wire strippers, or scissors, due to the hazard of metal-to-metal contact.

The second type of non-electric detonation system is the shock tube. The system utilizes a dust explosion in an almost empty tube to transmit the initiation signal. The tube is coated on the inside with a fine layer of HMX high explosive, combined with aluminum. The explosive is held on the tube wall by a static charge. When sufficient shock and ignition is delivered to the tube the dust explodes and the detonation is propagated through the tube in a fashion similar to a coal dust explosion in an underground mine. The tubing is insensitive to ordinary heat or impact, and requires high impulse shock to be energized. The most common initiation devices are mechanical devices, which utilize a shotgun shell primer activated by a firing pin. The reaction travels through the tube at a rate of approximately 6,500-7,000 fps. When the explosive reaction reaches a detonator it initiates the functioning of the delay elements in the detonator. With the exception of the ignition area, the detonator is very similar to one detonated electrically. Surface delay connectors, and down hole delay detonators are available for these systems making them very flexible and adaptable. The shock tube itself is made of a durable, flexible plastic, however, any cut or damage to the tube that might allow moisture to enter the tube could result in a cutoff of the detonation signal. The following is a list of precautions particular to the use of nonelectric shock tube detonating systems:

- Always store, handle, transport, and use all explosive products, including nonelectric systems, in accordance with the manufacturer's instructions.
- Only properly trained personnel should use nonelectric detonating systems.
- Always avoid situations where shock tube could become entangled, or entwined, with vehicles, machinery, or equipment.
- Protect the components of shock tube systems from unintended energy, such as, any source of heat, electricity, or impact.
- Always follow the manufacturers' recommendations when cutting and splicing lead-in trunkline shock tube.
- Never remove, or crimp, a detonator on shock tube.
- Never allow water, or moisture to enter a shock tube.
- Never hold shock tube in your hand while detonating, as the tube may rupture.
- Do not mishandle, or abuse shock tubing.
- Do not kink, pull, stretch, or put undue tension on shock tube.

- Never attempt to disassemble a surface delay detonator from the connector block.
- Never abuse shock tube by driving vehicles, or equipment, over it.
- Never attach the shock tube lead line to the initiating device until the blast area has been cleared.
- Since shock tube systems can only be checked visually, the blaster must use a systematic and orderly method of inspecting the hookup. Preferably, the visual inspection should be done twice to ensure proper connections of all tubing in the blast.

Non-electric systems vary from manufacturer to manufacturer; therefore always consult the manufacturer's recommendations for the product being used. Never mix systems from different manufacturers in the same blast unless specifically approved by the manufacturers.

## **Black Powder**

The modern commercial explosives industry has its roots in the development of black powder. The main ingredient of black powder was initially potassium nitrate (saltpeter), and is thought to have been used by the Chinese as early as the 10<sup>th</sup> century. Later explosive manufacturers were able to substitute sodium nitrate for the more costly potassium nitrate. Annual consumption of black powder in the U.S. is less than 100,000 pounds. Black powder forms the powder train in safety fuse, and has historically been used in the dimension stone industry in Virginia. In order for an operator to use safety fuse, or black powder, in Virginia they must first receive special approval from the DMM (**4 VAC 25-40-800.C.**). The approval would specify restrictions for handling, transportation, and storage of the materials.

## BLASTING INSTRUMENTS

### Testing Equipment

#### *Blasting Galvanometer*

A blasting galvanometer is an electrical resistance instrument designed specifically for testing electric detonators and circuits containing them. It is used to check electrical continuity. Other acceptable instruments for this purpose are blaster's multimeters and blasting ohmmeters.

#### *Blaster's Multimeter*

“The blaster's multimeter is a compact volt-ohm-millivolt meter specifically designed to measure resistance, voltage, and current in blasting operations.”<sup>8</sup> In all cases, instruments used to test blasting circuits should include the word *blaster's* or *blasting* in the name. **Standard electrical test meters must never be used to test blast circuits as they may deliver sufficient current to detonate all, or part, of a blast.** The blaster's multimeter can be used to: 1) measure the resistance of a single blasting circuit for continuity, and the total resistance in a series-in-parallel circuit; 2) survey blast sites to determine if extraneous current hazards exist; 3) measure a wide range of resistances necessary to investigate static electricity hazards, and; 4) measure power line voltages up to 1500 volts AC and DC.



<sup>8</sup> ISEE Blaster's Handbook, 17<sup>th</sup> Edition, Chapter 33, Blasting Equipment and Accessories, pg. 539.

## ***Blasting Ohmmeter***

The blasting ohmmeter is a digital or analog ('swing needle') device used to measure the resistance in ohms of a blasting circuit. The measurement is useful for:

- determining if the bridgewire of an individual detonator is intact
- determining the continuity of an electric detonator series circuit, and
- locating broken wires and connections in a series, or series-in-parallel circuit.

**If the special silver chloride battery in the blaster's ohmmeter is depleted it must be replaced with an identical battery. Never replace it with a standard battery.**



## **Blasting Machines (for electric detonator systems)**

The two basic types of blasting machines are: 1) generator; and 2) capacitor discharge (CD).

The generator type machine uses a small hand driven generator to produce a direct current pulse that energizes the electric detonators. The energy is generated by the twist of a handle, squeeze of a lever, or pushing down of a handle. The generator type machines are usually rated by the number of instantaneous, or delay, caps that they will successfully fire in a straight series. Under certain conditions these type machines may be used to detonate series-in-parallel circuits, but should never be used for straight parallel circuits.

CD blasting machines have a capacitor, or bank of capacitors that store a large quantity of electrical energy. The energy may be supplied by a high voltage battery, or by a high voltage oscillator from a low voltage battery. The blaster discharges the energy into the blasting circuit by activating a firing switch. The discharge of energy occurs in milliseconds. CD blasting machines will discharge many electric detonators in relation to their weight and size, and are a

reliable means of firing electric blasting circuits. The machines are rated in terms of voltage and energy, and blasters must consult the manufacturer's specifications to determine if the machine is sufficient for their application. The machines should always be used in accordance with the manufacturer's recommendations. **Persons using capacitor discharge blasting machines must be aware that the discharge from the machine can be lethal.** Blasting machines should be tested frequently by an approved tester, to ensure that the machine delivers its full output of energy.

Several CD blasting machines combined into a single unit is called a sequential timer. The timer is programmed so that it energizes multiple electric detonator circuits in a time delay sequence. The units provide blasters with a number of delays greater than those available when using electric detonators with a conventional blasting machine. They are especially useful where it is necessary to limit the amount of explosives per delay in order to control noise and vibration.



## Blasting Seismographs

A blasting seismograph is used to monitor, record, analyze, display, and print ground vibration and noise from a blast. It is used to measure the transfer of seismic wave energy from one point to another. Standard seismographs utilize four channels for signals from four sensors; three for ground motion and one for sound (air pressure). The data from blast events are shown as peak measurements of ground motion and air overpressure (also referred to as air blast). Ground sensors are contained in a geophone, which is placed in direct contact with the earth, and air overpressure is monitored through a microphone. Typical data registered are peak particle velocity (the speed at which a particle moves per unit of time), peak displacement (the distance particles are moved by the seismic wave), peak acceleration (rate of change in velocity per unit of time), and the frequency of movement (the number of cycles per second (hertz) that the particles vibrate). Air overpressure is a temporary pressure pulse above the atmospheric pressure level. Air overpressure is measured in pounds per square inch, and converted into decibels (dB).

Two examples of seismographs are shown on the next page.

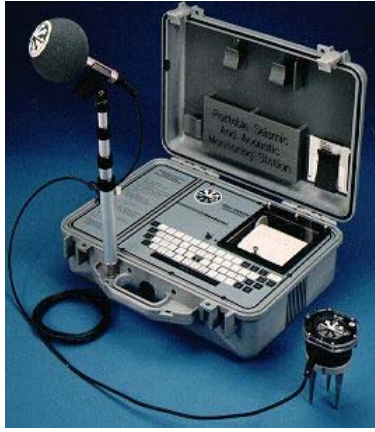

This page intentionally left blank.

## **SECTION 4**

### **BLASTING DESIGN / CONTROL**

This page intentionally left blank.

## SECTION 4 – BLASTING DESIGN/CONTROL

- Drilling
- Selection of Hole Diameter
  - Required Production
  - Terrain
  - Material Characteristics
  - Type and Size of Excavating and Hauling Equipment
  - Proximity to Vibration-Sensitive Areas
  - Bench or Lift Height
  - Explosives Type and Size
- Burden and Spacing
- Stemming
- Timing/Delays
- Scaled Distance
- Weather and Atmospheric Conditions
- Time of Day

# BLASTING DESIGN/CONTROL

## Drilling

In the surface drilling and blasting profession the most critical part is often the drilling portion. A blasthole is a cylinder whose prime purpose is to accommodate an explosive charge.

A drill log/report is the best way for a driller to communicate the condition of the blastholes to the certified blaster in charge of the blasting operation. 4 VAC 25-40-1095 requires the driller to produce a drill log as each hole is being drilled. The certified blaster in charge must review the drill logs to determine specific downhole conditions prior to loading a shot (**4 VAC 25-40-800.H.**).

The drill log/report must include, at a minimum, the following information per 4 VAC 25-40-1095:

1. the name of the driller.
2. borehole diameter.
3. borehole depth.
4. depth of broken material at the collar.
5. other geological conditions encountered (and the depth at which they are encountered) during drilling such as cracks, seams, voids, mud, or any other anomalies that could affect the blast.

The drill log should also:

- identify the borehole in the drill pattern,
- indicate the amount of overburden (loose, unconsolidated material lying above the rock being blasted),
- note the presence of water and at what depth it is located, and
- note whether subdrilling was done and how much.

A signed copy of the drill log must be provided to the mine operator and certified blaster in charge, and a copy included in the blast record (**4 VAC 25-40-1095**).

It is important that mine operators convey information related to their mine development plan to the drillers and blasters who will ultimately implement critical parts of the plan. The certified blaster in charge is responsible for designing a shot that meets the expectations of the mine operator, and complies with requirements of State and Federal mine law and regulations.

## Selection of Hole Diameter

In order to determine the appropriate hole size, or diameter, several important factors must be considered. We must also keep in mind that the most appropriate hole size may change over the life of the mining operation. It is generally accepted that the larger the blast

hole the less expensive the drilling cost, as long as the hole size remains appropriate for the operation. Some other factors to be considered are:

- Required Production
- Terrain
- Material Characteristics/Geology
- Type and Size of Excavating and Hauling Equipment
- Proximity to Vibration-Sensitive Areas
- Bench or Lift Height
- Explosives Type and Size

The capital investment available for initial startup is also a consideration. Of the factors listed above, geology is probably primary, as it is the one thing that cannot be altered. In hard, massive formations the distribution of explosives throughout the blast area is critical. Smaller holes, or a closer spacing, will result in finer fragmentation than larger holes on a wider spacing.

### ***Required Production***

Present and future production needs must be considered, as it will affect the type and number of drilling units required. However, production needs must be balanced against other considerations in order to come up with an appropriate hole size.

### ***Terrain***

In most cases, the larger the drill, the more limited it is in its ability to traverse rough terrain, and work in tight areas. For initial mine development, a smaller drill might prove more versatile than a larger unit, which might be more suitable to an established mine with a series of developed drill benches.

### ***Material Characteristics/Geology***

Some of the characteristics of the rock, or ore, that lend them to drillability and fragmentation, and that will also influence hole size are:

- **Hardness or compressive strength of the rock.** Percussive drilling is less affected by rock hardness than is rotary drilling. Hardness also relates to fragmentation, which can affect hole sizes in relation to explosive distribution.
- **Rock Structure.** The geology of the rock to be blasted also can affect selection of hole size. The existence of joints, fractures, folds, bedding planes and faults, as well as, the existence of cap rock will affect drilling operations. All the above factors influence fragmentation, back break, and stability of formations, which in turn affect economic efficiency of the drilling and blasting operation.

## ***Type and Size of Excavating and Hauling Equipment***

It is often thought that because large excavators and haulage equipment are used, blastholes will need to be as large as possible and the drill patterns spread in order to handle larger size blasted rock. To a degree this is correct, but it is important to keep in mind that the main purpose in using the larger excavation and haulage equipment is to promote higher levels of production more economically, not to cut costs on drilling and blasting. Thus, caution needs to be applied when making determinations of blasthole size based solely on the scale of excavation, haulage, and crushing equipment used. However, if the equipment used is relatively small in scale, careful assessment of the hole size, as it relates to the fragmentation desired, must be made.

## ***Proximity to Vibration-Sensitive Areas***

The majority of operators who utilize blasting and drilling techniques are very aware of restrictions placed on vibration, especially as it may relate to potential lawsuits. Larger holes contain more explosives per foot of hole, and unless decked, they will have higher charge weights per delay resulting in higher vibrations. In a new operation, some research and testing on hole size is advisable.

## ***Bench or Lift Height***

If benches have a fixed height, then blasthole size must be determined accordingly. Legislation dictates maximum bench height in certain areas, so some of the blasthole size selection process is eliminated. When bench height varies, there is much more latitude on hole size decisions; but in many cases bench or bank height is pre-set by production requirements and the size and type of equipment used.

Evaluation in determining bench or lift height should include:

1. The depth of the hole may be limited by the blow energy of the drill.
2. Steady State Velocity (The characteristic velocity at which a specific explosive at a given charge diameter will detonate).
3. The deeper the hole, the higher the percentage of explosives can be placed in the hole.

It is necessary to stay down a certain depth with the top of the explosive column in order to achieve desired results. To do this, the remaining depth of the hole must be filled with proper stemming. Since at detonation in an explosive column, energy is directed to the path of least resistance, it is generally necessary to “subdrill” or drill below the intended floor level. The path of least resistance, when properly designed stemmed, and subdrilled, should be the burden distance. Larger diameter holes are generally farther apart, so subdrilling is somewhat greater in order to break between the holes and avoid causing high bottom. The length of the explosive column is the bench height plus the subdrilling minus the stemming.

The relationship between hole diameter and bench height cannot be over emphasized. The use of a hole diameter that is too large for the respective bench height will result in poor explosive distribution. If stemming is decreased to allow the explosive column to reach farther up the blasthole, the possibility of flyrock and noise increases.

### ***Explosives Type and Size***

The explosive type, size and method of loading should be a consideration in selecting drill hole diameter. The larger the column of explosive the more it will maintain its Steady State Velocity. The larger blastholes will produce more tons/yards of material, which could show a cost saving per foot drilled. The blasthole diameter is an important part of the drilling and blasting operation, and will contribute to the cost and safety. In achieving the desired results the blasthole diameter may be changed several times during the life of the operation.

## **Burden and Spacing**

Burden is the distance from the drill hole to the nearest free face or the distance between drill holes measured perpendicular to the spacing. Also, the total amount of material to be blasted by a given hole is usually measured in cubic yards or tons. A rule of thumb for burden is two times the drill hole diameter in inches equals the distance to the free face in feet.

Spacing is the distance between drill holes. In bench blasting, the distance is measured parallel to the free face and perpendicular to the burden. A rule of thumb for spacing is one and a half times the burden.

### ***Drilling Patterns***

There are many types of drill patterns. The most frequently used are square, rectangular, and staggered. The square pattern has equal burden and spacing. The holes in each row are aligned directly behind the holes in the row in front of it.

In the rectangular pattern, the burden is less than the spacing. The holes in each row are again aligned directly behind the holes in the row in front of it.

The staggered pattern may have equal burden and spacing. However, it is used more often with the burden less than the spacing. The holes in alternate rows are in the middle of the spacing of the row in front of it. The staggered pattern usually requires extra holes to achieve a uniform bank on each end of the blast.

Where a cap rock condition exists, “helper” or “satellite” holes may be added to any drill pattern. These are short holes drilled only to sufficient depth to go to the base of the hard capping layer. They are drilled in offset rows, equidistant from the nearest standard-depth holes. The powder load for these holes is typically limited in order to avoid flyrock problems.

## **Stemming**

Stemming is defined as inert material placed in a borehole on top of or between separate charges of explosive material. It is used for the purpose of confining explosive materials or to separate charges of explosive material in the same borehole. A rule of thumb for stemming is two times the diameter of the borehole in inches equals the distance in feet.

If flyrock is encountered coming from the top of the blast or excessive air blast levels are recorded, the stemming should be increased. The size and type of stemming can also have an effect on the amount of stemming. In general the stemming amount should equal the burden of the blasthole. In cases of high hazard the stemming may need to be increased.

A rule of thumb for larger blastholes is to use stemming sized to 1/20<sup>th</sup> of the hole diameter. The desire is to create a locking effect between the stemming and the side of the blasthole.

Drill cuttings should not be used as stemming as they may contain a large amount of fine material. In dry holes, drill cuttings will not lock with the wall. In wet holes, the cuttings may mix with water and create a high specific gravity mixture that may lift the explosive causing separation and decrease stemming length in the blasthole. This may cause flyrock, excessive air blast (air overpressure), leave undetonated explosives in the muck pile, or create poor fragmentation.

## **Timing/Delays**

Millisecond (MS) delay blasting was introduced in open pit quarry blasting many years ago. Even when blasting to a free face, the rock movement time can be an important factor. This is particularly true in multiple row blasts. For a typical quarry with 15-foot spacing, the initial movement at the free face may occur in 10 to 12 milliseconds, but the burden only moves about 0.5-foot in 10 milliseconds. With one or two rows of holes, the prime movement is directly out from the face. As the number of rows increases, the rock movement will tend toward the vertical. The low velocity of the broken rock successively reducing the relief toward the free face causes this. This can contribute to “tight” bottom as well as flyrock.

It is a common practice of many blasters to double the delay time on the last row. This provides additional time for the rock ahead of the last row to move forward so that the relief on the last row will be increased. This practice called “skipping a period” will also reduce the upward ripping action and materially reduce the backbreak on the face.

When the blast consists of as many as eight or nine rows, the timing on MS delays should provide the additional time without skipping a period. The NO. 1 through NO. 8 periods (25 through 200 MS) will provide a nominal 25 milliseconds between each period. NO. 8 through NO. 15 (200 MS through 500 MS) will provide a nominal 50 milliseconds between each period. NO. 15 through NO. 19 (500 MS through 1,000 MS) will provide a nominal 100 milliseconds between each period. **This sequence is provided only as an example: the actual sequences and intervals of detonator timing vary with manufacturer.**

Always base timing designs on the limitations of detonator accuracy since delays of a given period have a range of actual firing times. Check with your supplier to avoid overlap or crowding.

Even with additional time between rows, the tendency still exists for the rock to stack if the number of rows is excessive. The hole diameter, burden and spacing, and height of face all have a pronounced effect on the number of rows that can be fired successfully without excessive stacking or creating high bottom. When the rock is broken, it will occupy on the average 30 percent more volume (this is termed “swell factor”) than it did in the solid (swell factor will vary with the type of rock). In most cases, the material has only two directions to move: to the front and vertically. Obviously, excessive movement in either direction will result in dangerous flyrock. If the number of rows is excessive, forward movement is limited, thus additional space for forward expansion cannot be provided.

The number of rows of large-diameter holes on wide burden and spacing that can be successfully blasted will be less than the number of rows of small-diameter holes on close burden and spacing. The reason for this is that the movement of the front rows with large-diameter holes will not provide the necessary space required for expansion. For the same reasons more rows of shallow holes, 25 feet deep or less, can be successfully blasted than holes 60 feet deep.

MS delay detonators allow the blaster to design the blast to take advantage of the relief provided by the natural terrain, or to create points of relief by the pattern design. They also allow the blaster to control the direction of rock movement within the limits of the natural contour and geology of the formation.

## Scaled Distance

4 VAC 25-40-880.B. requires seismic monitoring of each blast, unless the scaled distance,  $D_s$ , as calculated with the following scaled distance formulas, is 90 or greater:

$$W = \left( \frac{D}{D_s} \right)^2 ; D_s = \frac{D}{\sqrt{W}}$$

Where,

W = Maximum charge weight of explosives per delay period of 8.0 milliseconds or more.

D = Distance in feet from the blast site to the nearest inhabited building not owned or leased by the mine operator.

Scaled Distance ( $D_s$ ) means the actual distance (D) in feet divided by the square root of the maximum explosive weight (W) in pounds that is detonated per delay period for delay intervals of eight milliseconds or greater; or the total weight of explosives in pounds that is detonated within an interval less than eight milliseconds.

For example, if the nearest inhabited building not owned or leased by the mine operator is 1,800 feet away, then the maximum charge weight of explosives (W) that would be allowed without seismic monitoring would be: the square of 1,800 feet divided by 90 or  $(1800 / 90)^2$ , which equals 400 pounds. This means an operator could blast one hole per delay containing 400 pounds of explosives, two holes per delay containing 200 pounds of explosives, or four holes per delay containing 100 pounds of explosives.

**4 VAC 25-40-880.A.** states that ground vibration, measured as peak velocity resulting from blasting, shall not exceed the limits set forth below at any inhabited building not owned or leased by the mine operator, without approval of the director. A seismograph record is also required for each blast.

Distance (D) to Nearest inhabited Building, feet	Peak Particle Velocity, inches Per second
0-300	1.25
301-5,000	1.00
5,001 and beyond	0.75

The total energy of the ground motion wave generated in the rock around a blast varies directly with the weight of charge detonated. As the ground motion wave propagates outward from a blast, the volume of rock subject to the compression wave increases. Since the energy in the ground shock is distributed over successively greater volumes of rock, the peak ground motion levels must decrease.

## **Weather and Atmospheric Conditions**

Prior to bringing explosives and detonators to the blast site, weather conditions shall be monitored to ensure safe loading and firing, 4 VAC 25-40-800.G.

Atmospheric conditions such as temperature inversions and surface winds can affect the air blast pressure (air overpressure) considerably. The direction and speed of any wind can also affect the travel of an air blast wave. The air blast wave will be bent in the direction that the wind is blowing to a degree depending on the wind speed. Because of the fact that wind speed is usually lower at ground level than it is higher up, the rays may even be bent back to the earth's surface by the wind.

If the proper temperature inversion and wind speed and direction conditions are present at a blast site, it is possible that their effects may combine to produce air blast wave travel. The inversion-bent and wind-carried wave might produce a focal point of high overpressure downwind from the blast site. Air blast (air overpressure) complaints are apt to be heard if the

focal point is near an occupied building or in a residential area. Downwind focusing of an air blast wave reportedly could increase the overpressure by a factor of as much as 100.

It has been found that windows are probably the weakest part of a structure that will be exposed to air overpressure; they are most apt to suffer damage. Poorly mounted panes that are pre-stressed will be cracked and broken most easily. Extremely high overpressure could cause the formation of exterior masonry cracks or interior plaster cracks.

Although it is possible that high air blast overpressure (air overpressure) could cause structural damage; those produced by routine blasting operations under normal atmospheric conditions are not likely to do so. The principal effects are most often: 1) a slight overpressure that rattles windows, and, 2) noise that startles people. The rattling windows and noise may leave them under the impression that their house was violently shaken by blasting. Complaints may result if the subjective response of the people is such that the disturbance is annoying or intolerable.

In situations where air overpressure from production shooting can be a problem, it is often customary to fire a small surface shot and measure the peak overpressure at the point of interest. If a normal reading is obtained, then the main production shot is fired. If it is excessively high, then the blast should be delayed. Local meteorological information can be obtained from local weather stations, airports, and smoke rising from smoke stacks.

## **Time of Day**

Boreholes to be blasted shall be loaded as near to the blasting time as practical. Loaded shots shall be blasted as soon as possible upon completion of loading and connection to the initiation device. **Surface blasting shall be conducted during daylight hours only (4 VAC 25-40-800.I.).**

This page intentionally left blank.

## **SECTION 5**

### **BLAST EFFECTS**

This page intentionally left blank.

## **SECTION 5 – BLAST EFFECTS**

- Introduction
- Air Overpressure (also known as Airblast)
- Ground Vibration
- Blasting Restrictions-Air Overpressure and Ground Vibration
- Flyrock

# BLAST EFFECTS

## Introduction

The public relations problems involving blasting have increased in the past years. The increased difficulty that blasters face with public relations is the result of urban expansion and the commencement of surface operations near densely populated areas. When blast effects intrude upon the public's comfort, strained relations usually arise between operators and surrounding communities.

The two most common complaint problems are air overpressure (also referred to as air blast) and ground vibration. Blasting produces air overpressure and ground vibration that can result in structural response at off-site buildings. This perceived motion could be very disturbing to homeowners; therefore, it is advantageous to establish good public relations with nearby neighbors. Most homeowners mistakenly believe that any motion of window glass or house structure originates from ground vibration striking the foundation of the house, when in fact the concussion element of air overpressure is often the culprit. DMM Safety & Health Regulations establish maximum limits for both ground vibration (4 VAC 25-40-880) and air overpressure (4 VAC 25-40-890) based on comprehensive studies conducted by the U.S. Bureau of Mines (USBM).

Explosive manufacturers, mine operators and government agencies have spent substantial amounts of time and effort in order to gain a better understanding of the relationships between blast variables and the blast effects of air overpressure and ground vibration. Much knowledge has already been gained and numerous studies have yielded guidelines for the case of delay blasting and modern monitoring techniques. These studies and guidelines, if used, will help reduce the likelihood of damage to domestic structures and hopefully reduce the number of public complaints. The process by which blasting causes damage to structures is not a well-defined process. While the variables of the blast design can be controlled, there is some variation in the strength of an explosive and the actual delay time between the individual explosions that comprise a round. There is substantial random variation in the vibration propagation characteristics of the rock, the air overpressure propagation characteristics of the atmosphere (weather changes), and the strength and the ability of the nearby man-made structures to withstand the stresses of the blast without breaking. This means that until a substantial body of experience has been collected at a given site, there is a small likelihood that the next blast will produce more damage than the last one of like size. This must be kept in mind when assessing blasting safety.

Blasters can overcome the complaints about noise and vibration through careful blast design with effective use of delays, by careful monitoring of the blast effects, and by meeting with neighbors to explain the care and safety precautions used to protect their property and themselves. Communication and keeping the public constantly informed are a big factor that will help to reduce the number of complaints. Blastors must continue to analyze blast design, monitor blasts effectively, and maintain accurate records in an effort to reduce persistent complaints. The records of blast design and blast effect are very important factors when government agencies investigate and discuss the problems of complaints.

## **Air Overpressure**

In order to help reduce and or avoid air overpressure complaints, a blaster must understand the relationship between an explosive blast, weather conditions and an air overpressure.

The air overpressure from an explosive detonation is a compression wave in the air. It is caused either by the direct action of explosive products from an unconfined explosive in the air or by the indirect action of a confining material subjected to explosive loading. Noise is the portion of the spectrum that lies in the audible range from 20 to 20,000 hertz. The concussion of a blast results from the spectrum below 20 hertz. Air overpressure is described in terms of the maximum pressure in pounds per square inch (lb/inch<sup>2</sup>), or in terms of the sound pressure level measured in decibels (dB). Figure 5-1 may be used to convert from one scale to another. As shown on Figure 5-1, 140 dB is the threshold of pain, 85 dB is normal street traffic, 40 dB is a background noise level in the home, and zero is the threshold of hearing.

Air overpressure is measured with a specialized microphone attached to a seismograph in dBs or lb/inch<sup>2</sup>. Current DMM S&H Regulations limit air overpressure to 133 decibels at any inhabited building not owned or leased by the operator. (4 VAC 25-40-890)

All of the energy liberated by the explosive is initially in the form of a highly compressed gas. Some of that gas escapes to the surface and travels through the air as air overpressure. The largest part of the compressed gas energy goes into breaking and moving rock. The sudden movement of the rock at its face or at the ground surface also causes a disturbance, which propagates through the air. Parts of these disturbances are in the audible range of frequencies (>20 Hz) and are collectively called noise. Some of these disturbances are in the sub-audible range. Both parts together are called air overpressure. If sufficiently intense, they can cause buildings to vibrate and crack, windows to vibrate or break and discomfort or pain to individuals.

Atmospheric conditions affect the intensity of noise from a blast at a variable distance. These conditions determine the speed of sound in air at various altitudes and directions. The speed of sound is determined primarily by two factors: (1) temperature and (2) wind speed. Normally the air temperature decreases as the altitude from the earth's surface increases. A temperature inversion exists if the air becomes warmer as the altitude increases.

If the weather conditions (temperature and wind velocity) are such that a greater sound velocity in any direction occurs above the earth's surface, a sound speed inversion exists and therefore bends the sound rays back toward the earth's surface.

When a temperature inversion exists, the temperature and sound velocity increase with altitude. The sound rays will bend back toward the earth's surface but will decrease more slowly with distance than with a sound speed inversion.

Conversely, when the temperature decreases with altitude and sound speed, the sound rays are refracted away from the earth's surface. This condition is more stable and is the most frequent condition during the time of the most surface blasts. With this condition, the noise level decreases rapidly with distance.

Figure 5-1. Sound Level Conversions

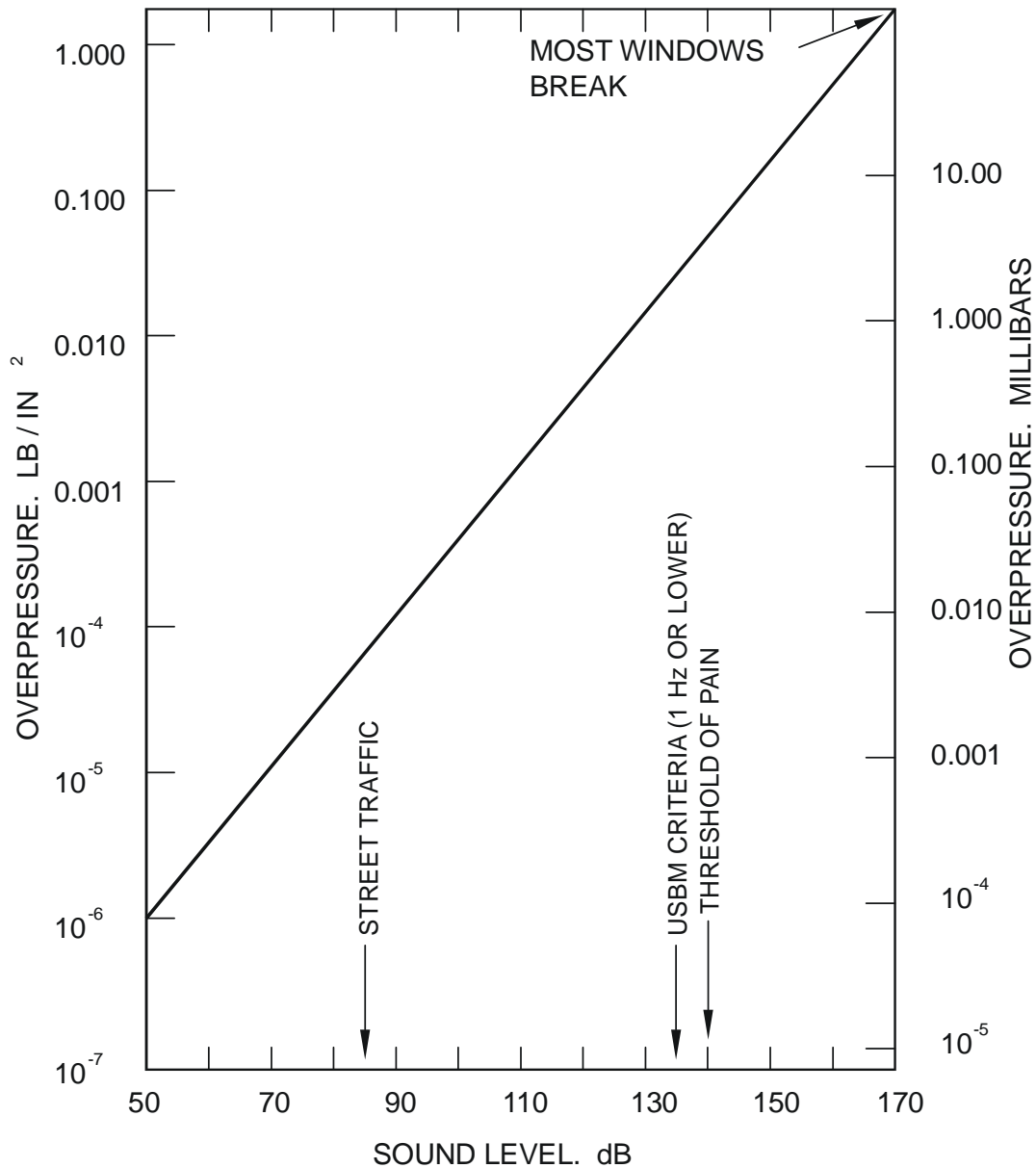

In the early morning, a temperature inversion may be present following clear nights with low wind speeds that prevent mixing of the atmosphere. The lack of cloud cover allows the temperature of the ground and air above it to drop rapidly creating the inversion. Blasting done in the early morning will result in loud noise levels. As mid-morning arrives, the sun's rays will cause the ground temperature to warm and rise and the increased ground temperature warms the air in contact with it. This process will continue throughout the day and the mid-morning. At this time, favorable conditions for blasting are present. Near and after sunset, the temperature of the earth's surface begins to cool and a low altitude inversion may exist.

The presence of cloud layers signifies the presence of a temperature inversion. The commonly accepted idea that noise is reflected from the bottom of clouds is mistaken. The clouds signify the presence of an inversion, which reflect the sound back toward the earth's surface.

Changes in sound velocity with altitude may also be caused by wind. Wind is highly directional. Normal wind increases with altitude and therefore causes an increase of sound speed with an increase of altitude. The wind direction may result in an increase or decrease in noise levels in the down wind direction. The effect of wind on noise levels is generally the greatest in the winter months because of the higher wind speed that is present during this time of year. In the warmer months, wind speeds are normally lower and help prevent the formation of temperature inversions.

The following are favorable atmospheric conditions for blasting:

1. Clear to partly cloudy skies, light winds and a steady increasing air temperature from daybreak to shot time.
2. Blast time should be delayed to at least mid-morning to allow early morning temperature inversions, if present, to be eliminated.

The following are unfavorable atmospheric conditions for blasting:

1. Foggy, hazy or smoky days with little or no wind or conditions associated with temperature inversion.
2. During strong winds accompanying the passage of a cold front.
3. During periods of the day when the surface temperature is falling.
4. Early in the morning or after sunset on clear days.
5. Cloudy days with a low cloud ceiling, especially when there is little or no wind.

Air overpressure is usually caused by one of three mechanisms. The first cause is energy released from unconfined explosives such as uncovered detonating cord trunklines or mudcapping used in secondary blasting. The second cause is the release of explosive energy from inadequately confined borehole charges resulting from inadequate stemming, inadequate burden or mud seams. The third cause is movement of the burden and the ground surface. Blasts are designed to displace the burden. When the free face moves out, it forms an air compression wave that results in air overpressure. For this reason, locations in front of the free face receive higher air overpressure levels than those behind the free face.

The following are typical air overpressure sources for most blasting projects.

1. The air pressure pulse (APP), caused by the sudden outward displacement of the rock face, is a low frequency pulse.
2. Conversion of ground surface vibration to air vibration at some distance from the explosion called the rock pressure pulse (RPP) or in seismological literature, air coupled ground roll.
3. Venting of the explosion produces gas to the surface through broken rock, called the gas release pulse (GRP).
4. Escape of explosion produced gases to the surface up the drill bole after the stemming is blown out, called the stemming release pulse (SRP).
5. Explosion of detonating cord exposed on the ground surface, which produces a high frequency pulse, called the surface detonation pulse (SDP).

Structural effects of most common concern are window breakage and plaster cracking. Research has largely been limited to single-family houses. Overpressures of only 0.03 PSI can vibrate loose window sashes, often to the annoyance of the public, but without permanent damage. Air overpressures of 1.0 PSI will break most windowpanes and as pressures exceed 1.0 PSI, plaster in flexible walls will crack. Windows and plaster that have been stressed previously, that is by house settlement may be damaged at pressures down to 0.1 PSI.

The odds of a large window being broken were indicated to be 1/10,000 at 0.012 PSI. Similar odds for small windows exist at 0.030 PSI. For common practice, 0.1 PSI (130 dB) can be taken as the safe limit for window glass (Figure 5-1). Air overpressures are relatively strong sources of midwall vibrations, and poor sources of corner (whole-structure racking) vibration. The air overpressure levels producing the same amounts of corner vibration as 0.50 in./sec ground vibration are 0.020 to 0.024 lb/in. squared (137 to 138 dB). Air overpressures with 0.007 to 0.009 lb/in. squared (128 to 130 dB) produce wall vibration equivalent to that from 0.50 in./sec. ground vibration. From these equivalencies, air overpressure appears less likely to crack walls than ground vibration.

When a large number of explosive charges are detonated with small time delays between them, the air overpressure pulses from the individual charges may superimpose in a given direction and produce a strong air overpressure.

An air overpressure, whether audible or inaudible, can cause a structure to vibrate in much the same way as ground vibrations. Air overpressure is measured with a blasting seismograph. Both amplitude and frequency are measured. The amplitude is measured in decibels or pounds per square inch and frequency is measured in hertz. Air overpressure from a typical surface blast has less potential than ground vibration to cause damage to structures. However, air overpressure is a frequent cause of complaints. When a person senses vibration from a blast or experiences house rattles, it is usually impossible to tell whether ground vibrations or air overpressure is being sensed. A thorough discussion of air overpressure is a vital part of any surface mine-public relations program.

Because air overpressure is a major cause of blasting complaints, some operators choose to seismograph all surface blasts. Air overpressure, though, does result in a potential for structural damage.

Air overpressure recordings provide good evidence in case of complaints or lawsuits. Air overpressure readings taken in conjunction with ground vibration readings are especially helpful in determining which of the two is the primary cause of complaints. Sound travels faster in warmer air due to the air molecules being less dense than in colder air. Also, the speed and direction of the wind can cause a "focusing" affect of the concussion and sound waves.

Properly executed blasts, where surface explosives are adequately covered and borehole charges are adequately stemmed, are not likely to produce harmful levels of air overpressure. Careful attention to and adjustment for the following details will usually improve results by reducing air overpressure, and, subsequently, the number of complaints:

The following are methods of controlling air overpressure:

1. Avoid the use of unconfined explosives:
  - (a) Bury detonating cord one foot or more;
  - (b) Use low-load detonating cord if possible;
  - (c) Never adobe or mudcap in populated areas unless necessary.
2. Use adequate stemming:
  - (a) Use crushed stone for stemming in wet holes for better confinement and to avoid densifying water with drill fines so that low-density charges may float;
  - (b) Use additional stemming on the front row if excessive backbreak from the previous shot is present.
3. Use drill patterns having nearly equal burden to spacing ratios.
4. Use a longer delay interval between rows than between holes in a row.
5. Be sure the blast proceeds in the proper sequence.
6. Consider geologic abnormalities:
  - (a) Use nonexplosive decks through mud-dirt seams, weak seams, etc.;
  - (b) Have drillers report cavities that could be overloaded with explosives;
  - (c) Avoid or backfill cavities and day-lighted seams;
  - (d) Maintain accurate drilling records;
  - (e) Check the drillers' log to get an accurate analysis of all boreholes.
7. Schedule shots at times when neighbors are busy; not at home or when they expect blasting to occur.
8. Avoid excessive delays between holes.
9. Consider beam formation when designing blasts:
  - (a) Minimize the number of opening holes having the same delay period;

- (b) Avoid the use of long charges in boreholes whose length is large when compared with the burden of the hole.
- 10. Evaluate topography for burden and focusing effects. Orient face to avoid facing built-up area.
- 11. Analyze weather for temperature inversions, wind and low cloud cover.
- 12. Test-shoot and develop site-specific criteria.

Good pre-blast planning again is important. Follow the drill pattern closely, provide adequate stemming in boreholes - at least equal to the burden, blast during favorable weather conditions, and cover any trunk lines or any other explosive devices to minimize the air overpressure effects.

### **Ground Vibration**

The public relations problem of ground vibration that is associated with the use of explosives is just as prevalent as the air blast problem. Once again, manufacturers, explosive consumers and government agencies have spent a vast amount of time and effort to gain a better understanding of ground vibration.

The detonation of an explosive contained in a drill hole or series of drill holes generates a large volume of high-temperature (2,000-5,000° C), high-pressure ( $0.2 \times 10^6$  to  $2.0 \times 10^6$  PSI) gas. The sudden application of this pressure to the cylindrical surface of a drill hole generates a compressive radial stress and strain in the rock. This wave crushes the rock that immediately surrounds the borehole. The boundary that surrounds the crushed rock area represents the area of the blast-fractured zone. The waves attenuate (decrease) in amplitude with increasing radius, R, from the explosive and at some distance no longer produce breakage but only vibration of the ground. Figure 5-2 shows a plan and cross section view of an idealized single hole blasting operation and is used to define some terms of interest. At any point, the displacement of the ground can be resolved into three perpendicular components:  $U_R$  (radial),  $U_V$  (vertical), and  $U_T$  (tangential). For reasons to be explained below, it is customary to express damage criteria, and to predict and to measure ground vibration, in terms of the three orthogonal components of velocity--  $U_R$ ,  $U_V$ , and  $U_T$ . When the intensity of the stress wave is reduced so that there is no permanent deformation of the rock, the wave propagates through the rock in an elastic manner such that the rock particles will return to their original position following passage of the stress wave. The stress waves travel through the earth causing rock particles to vibrate. All blasts create ground vibration. This situation is similar to the circular ripples produced on the surface of calm water when struck by a rock. Ground vibrations are measured with a seismograph machine. Vibrations are measured in terms of amplitude (size of the vibrations), measured in inches per second of peak particle velocity (PPV), and frequency (number of times that the ground moves back and forth in a given time period), measured in velocity in hertz or cycles per second. Excessively high ground vibration levels can damage domestic structures. Moderate to low levels of ground vibration can be irritating to neighbors and can cause complaints and or legal claims of damage and nuisance

**Figure 5-2. Plan and Cross Section**

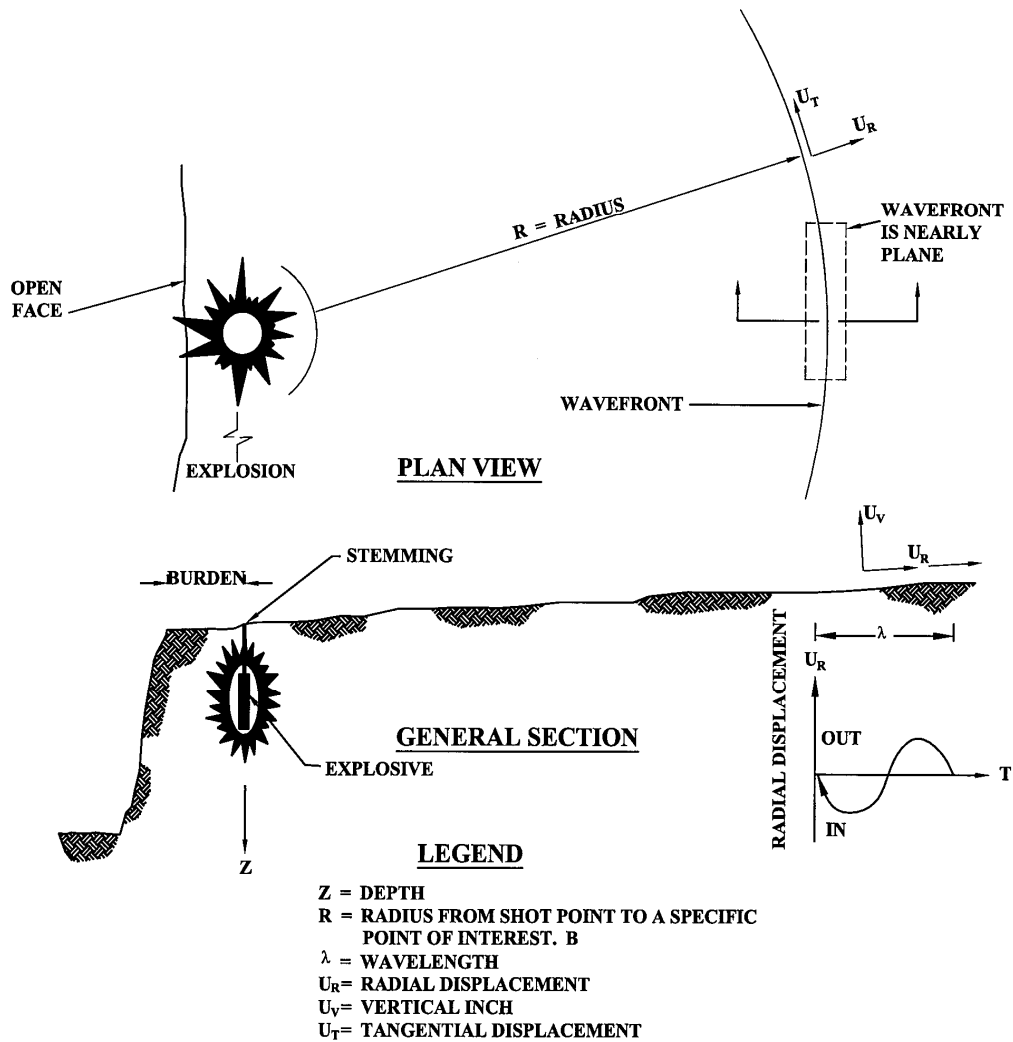

Studies have shown that high frequency wave energy is absorbed more readily than low-frequency wave energy so that the energy content of stress waves at large distances is concentrated at low frequencies. The velocity is referred to as particle velocity in order to distinguish this quantity from propagation velocity. The peak particle velocity of ground vibration depends on the maximum charge-weight-per-delay of eight milliseconds or more and not on the total charge weight of the blast. The most significant ground motion parameter is the maximum radial particle velocity  $U_R$ , which is usually the maximum of the three components at the radii of interest.

Various kinds of stress waves travel at different speeds and interact in a complicated manner with themselves and the material in which they travel. A blast that finishes detonating

in a few hundred milliseconds or less can produce ground motion for several seconds at locations several hundred yards away. A process known as dispersion, whereby the different frequencies travel at different velocities, enhances the lengthening of ground motion with distance.

The amplitudes of ground vibration at a given distance from an explosion increases with the following:

1. The energy in the explosion. Energy is the capacity to do work (the fracturing and movement of rock and the creation of air and ground-transmitted shock and vibration) and is directly proportional to the weight of explosive. Energy (W) is a weaker function of the type of explosive used. For practical purposes, all commercial explosives in use today can be taken as having the same energy/unit weight. The number of explosives (delays) fired in round times the energy per delay determines the total energy in the round. It is common practice to express energy in units of pounds of explosive, although in a strict sense energy should have units of force times distance.
2. The confinement of the explosive by the burden (see Figure 5-2) and stemming. It is usual practice to stem all holes to minimize airblast effects. Pre-split shots have a semi-infinite burden. The confinement of the explosive determines the partitioning of the energy among rock breakage, ground vibration and airblast. The greater the confinement, the more energy directed into rock breakage and vibration and the less to airblast. Hole spacing and sequence of firing also impact confinement.
3. The type of rock has a weak influence on maximum particle velocity. The denser the rock, the higher the peak particle velocity close to the explosion. At large distances, the reverse is sometimes the case. However, the effect of the type of rock is so weak that it is usually ignored in preliminary estimates of ground motion and it is automatically accounted for in project specific, ground motion curves developed by physical observations.

Blasters can overcome the vibration complaints through careful blast design, the effective use of delays, and by careful monitoring of the blast effects. The best protection against complaints and damage claims is good public relations. The blaster should inform local residents of the need and importance of blasting. A blaster should also stress the relative harmlessness of properly controlled blasting vibrations. In situations where complaints persist, continued attention to blast design, effective monitoring and good record keeping will be of invaluable importance. Prompt and sincere response to complaints is vital.

Blasting induced ground motion has some important characteristics. In close-proximity to a blast, the predominant frequencies exceed 100 Hz and the vibration drops off sharply with distance. In general, frequency will decrease as the distance from the explosion increases and the maximum particle velocity will decrease.

Excessive ground vibrations are caused by either putting too much explosive energy into the ground or by not properly designing the shot. Part of the energy that is not used in fragmenting and displacing overburden will go into ground vibrations. The vibration level at a specific location is primarily determined by the maximum weight of explosives per delay period and the distance of that location from the blast. The delays in a blast break it up into a series of smaller, very closely spaced individual blasts. The longer the intervals between delays the better the separation will be between the individual blasts. Eight milliseconds is the minimum delay that can be used between charges if they are to be considered as separate charges for vibration purposes. In addition to charge weight per day, distance and delay interval, two other factors affect the level of ground vibration. The first factor is overconfinement. A charge with a properly designed burden will produce less vibration. The second factor is an excessive amount of subdrilling. Excessive subdrilling will cause an extremely heavy confinement of explosive energy. In multiple row blasts, there is a tendency for the later rows to become overconfined. To avoid this, it is often advisable to use longer delay periods between the later rows to give better relief.

Two vibration limits are important; the level above which damage is likely to occur and the level above which neighbors are likely to complain. There is no precise level at which damage begins to occur (Table 5-1). How much actual ground movement takes place determines whether structural damage will occur to buildings off the mine site. The lower the frequency produced, the more likely that structural damage can occur (Figure 5-3). Frequency waves below 20 Hz are inaudible but are capable of producing structural vibration and damage.

**Table 5-1. Categories of Building Damage**

<b>Damage to buildings can be grouped in three categories</b>	
Threshold:	Formation of new minor cracks in plaster or at joints in wallboard, opening of old cracks and dislodging loose objects.
Minor:	Superficial, not affecting the strength of the structure; for example, loosened or fallen plaster, broken windows, significant cracks in plaster, hairline cracks in masonry.
Major:	A significant weakening of the structure, large cracks, shifts of the foundation, permanent movement of bearing walls, settlements which cause distortion of the structure or walls out of plumb.

**Figure 5-3.**

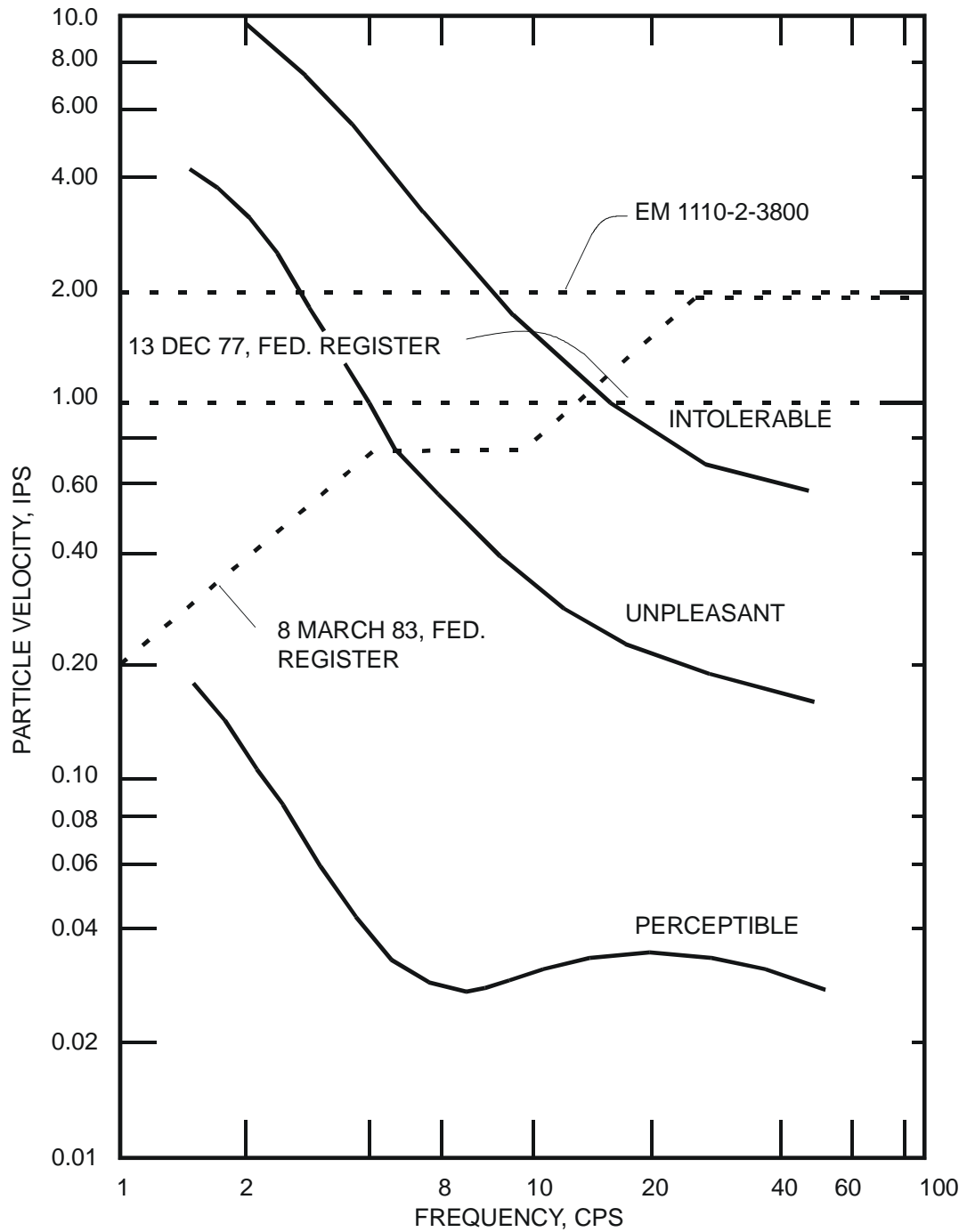

- - - - - VARIOUS RESIDENTIAL STRUCTURE TOLERANCE LIMITS  
 ————— HUMAN RESPONSE

The damage level depends on the type, condition, age of the structure, the type of ground on which the structure is built and the frequency of the vibration. People tend to complain about vibrations far below the damage level. The threshold of a complaint depends on complainant health, fear of damage, attitude toward the mining operation, diplomacy of the mine operator, and how often and when blasts are fired and the duration of the vibrations. The vibration tolerance level is very dependent on local attitude toward mining. Careful blast design and good public relations are essential elements for an operator to live in harmony with neighbors in order to minimize complaints and avoid legal claims.

The intensity of stress waves that can be tolerated by various kinds of structures must be established before acceptable charge weights at various distances can be determined. The level of motion required to damage a structure depends upon its construction. For example, a steel-framed building can tolerate a more intense stress wave than a residential structure with plaster walls. Because plaster is the weakest of the most commonly used materials for construction and because of the prevalence of such structures, damage criteria is based on this type structure. Blasters may consult structural engineers who are able to specify permitted vibration levels for certain types or kinds of structures.

Good pre-blast planning is essential to ensure frequency waves resulting from the blast remain above the structural damage levels. This can be achieved by varying the duration of the blast, varying the pounds per delay of explosives, maintaining proper burden and spacing, or any combination.

The following is a list of steps that a blaster can take to help reduce ground vibration:

1. Use a blast design that produces the maximum relief that is practical. Explosions in boreholes, which have good relief and those having nearby free faces, produce less ground vibration. The use of delay blasting techniques establishes internal free faces, which reduces ground vibration. The proper design of delay patterns can help achieve maximum relief. In general, when blasting multiple row patterns, greater relief can be obtained by using a greater delay time between rows than between holes in a single row. A delay time between holes in a row of at least one millisecond per foot of burden is usually recommended for the necessary relief and maximum fragmentation.
2. Use the proper powder factor. An excessive powder factor will usually increase both ground vibration and air blast and may cause excessive burden displacement or fly rock. On the other hand, an insufficient powder factor will usually increase ground vibration by delaying or reducing the effect of stress waves reflected off the free faces. The optimum powder factor must be determined by experimentation at any given blasting site and used.
3. It is necessary to reduce the charge/delay to some value that will produce a maximum particle velocity less than those in the damage criteria. To achieve the desired fragmentation, it is necessary to keep the powder factors above some minimum level. Powder factor is defined as weight of explosives in pounds per cubic yard of rocks to be excavated. Depending on the type of rock, the burden, and the maximum fragment size desired, the proper power factor will usually range from 0.5 to 1.0 lb./cu yd. To

accomplish both purposes it is sometimes necessary to increase the number of shot holes drilled. If no delays are being used, the obvious first step is to introduce the use of delays. This can be done up to the point where the explosive in each borehole is fired separately by using a combination of millisecond delays and a multiple circuit blasting machine. If this is not sufficient, decking of the charge within the borehole should be considered. This technique involves several charges separated by 5 ft or more of stemming the same hole, with one fired after the other through the use of delays. If it was originally necessary to fully load the hole to get the desired powder factor, decking will require either a larger diameter shot hole or more shot holes at a closer spacing. Since the loading, wiring and initiation of decked shots are more complex; this procedure requires greater experience. Alternatively, it may be desirable to avoid decking and simply reduce the spacing between shot holes. This option is not as complex but usually requires more boreholes.

4. Use a spacing-to-burden ratio equal to or greater than one, if possible. The presence of weak seams or irregular backbreak may dictate the use of a spacing-to-burden ratio less than one.
5. Control drilling of blast holes as closely as possible.
6. Keep the amount of subdrilling to the minimum required to maintain good floor conditions. A typical amount of subdrilling is 0.3 times the burden at floor level. Excessive subdrilling will usually increase ground vibration because of high confinement and a lack of a nearby free face.
7. Use various techniques to reduce charge-weight-per-delay which should in turn reduce the peak particle velocity:
  - (a) Reduce hole depths and reduce bench heights;
  - (b) Use smaller diameter holes;
  - (c) Subdivide explosive charges in hole by using inert decks and fire each explosives deck with an initiator of a different delay period;
  - (d) Use electronic timers to increase the available number of delay periods of electric blasting caps and to increase timing flexibility. Sequential timers are used for this purpose and are real effective in helping to shorten the duration of ground motion.
8. Use delay electric blasting caps or surface connectors to reduce the number of holes on a delay. If the time for a wave (compression) to travel from the shot hole through the burden to the face and be reflected back to the borehole as a different wave (tension) is less than the delay time between charges, the second charge is more confined and a greater amount of its energy results in vibration. If for multiple row blasts, the rock in front of the first row of borehole has not moved sufficiently forward before the detonation of the second row the confinement effect is also strengthened. In general, the longer the delay intervals within the millisecond range the better. This interval must be short enough that the round is not perceived by an observer to be a series of separated explosive events.

The threshold of cracking reported ranges from 0.8 to 11.8 in./sec. The data show that the higher the frequency of the maximum particle velocity, the higher the threshold. The data also show a trend in which surface mine blasting produces lower thresholds than quarry blasts which are in turn lower than construction blasting. This trend is consistent with the frequency effect as shown by the relation of the predominant frequencies in the three types of events in Figure 5-3.

When the maximum particle velocity component in any direction exceeds 2.0 in./sec, the threshold of cosmetic damage begins. Minor damage begins at about 5.4 in./sec and major damage at about 7.6 in./sec. There have been more than 100 observations of residential structures at particle velocities in the 2-6 in./sec range where no blasting damage was recorded. The damage threshold particle velocity is a random variable and in the majority of cases, the threshold of damage will lie below 2 in./sec. The cases below the 2-in./sec level where some damage occurred are infrequent.

Threshold damage is always cosmetic in nature as it does not affect the usefulness of the structure but can result in an economic loss. Most minor damage such as cracking of masonry is also cosmetic in nature, but can cause loss of use of the structure until repaired. Most minor damage can be quickly repaired. In general, cracking is more likely to occur in older structures that have already suffered prestraining and fatigue, and in plaster, rather than in newer wallboard construction. Predominant frequencies observed in measurements of construction blasting range from 10 to 40 Hz while those from quarrying operations are in the 5-30 Hz range. Frequency decreases with range. Particular stratigraphic arrangements can enhance particular ground motion frequencies. Likewise, particular structural arrangements of buildings or components when excited by ground vibrations have a natural preference to vibrate at a particular frequency called a natural frequency. Typical natural frequency levels are shown in Table 5-2:

**Table 5-2. Typical Natural Frequencies**

<b>Structure or Element</b>	<b>Natural Frequency, Hz</b>
<b>Multistory Building</b>	<b><math>F = 0.1N</math> (N = number of stories)</b>
<b>Radio Tower 100 ft tall</b>	<b>3.8</b>
<b>Petroleum distillation tower 65 ft tall</b>	<b>1.2</b>
<b>Coal silo, 200 ft tall</b>	<b>0.6</b>
<b>Building walls</b>	<b>12 - 20</b>
<b>Wood frame residences (1 and 2 story)</b>	<b>7.0 (Standard deviation = 2.2)</b>

Most vibrations from construction blasting and nearly half of the vibrations from quarry operations are at frequencies above the range given above. A residential structure will respond less (that is, strain less) when shaken by a 1.0 in./sec maximum velocity ground motion at a principal frequency of 80 Hz than it will to a 10 Hz ground motion with the same maximum velocity. The structure tends to resonate (that is, vibrate at ever increasing amplitudes) when shaken by a ground motion with a large number of cycles at or near its natural frequency. While this tendency to increase without limit is controlled by damping and the transient nature

(nonsteady state) of the blasting induced ground-motion; increases of a factor of 4 in response due to this phenomenon are not uncommon. In the absence of velocity versus time data from a test blasting program at the site, from which frequency of ground motion can be determined, it is recommended that construction and quarry blasting peak particle velocities at the nearest residential structure be limited to 2.0 in./sec or less. Experience indicates the probability of damage to residential structures is at or below this level will be very small.

Observations by the Bureau of Mines have shown recorded particle velocities of 0.75 in./sec for modern residences, and 0.5 in./sec for older structures have little or no effects. The Bureau of Mines indicates that one of the motivations for these levels were human irritation with, and tolerance of, repeated blasting operations. The Bureau of Mines established a 1.0 in./sec criteria for commercial surface mining blasting in the proximity of human habitation and DMM adopted this as well (4 VAC 25-40-880). Also, DMM has adopted criteria to permit alternate use of the allowable maximum velocity-frequency chart (4 VAC 25-40-880). The design engineer or equivalent should consider the age of the structures, the condition of the structure, the type of blasting (construction or quarry), and pick a threshold value consistent with the expected frequency content of the motion and the appropriate level of risk of damage. Comparison of human response to steady state vibration as a function of frequency and various blasting vibration criteria for residential structures.

Figure 5-4 shows the effect of steady state vibration on individuals determined from a systematic research program. Blasting vibration is transient and less disturbing.

The effects of transient motion with and without accompanying noise and observer bias are presented in the table below.

Table 5-3 and Figure 5-3 indicate that humans are less tolerant of low frequency blasting vibrations than are buildings, and that accompanying noise and bias against the project at which the blasting is being done makes them more unwilling to accept transient vibration. The previous table indicates that repeated blasting operations with maximum particle velocities of over 1/2 in./sec at occupied structures will produce complaints and that operation at the 1/4 in./sec level may in some cases result in complaints. Good blasting practice includes consideration for these human responses at offsite locations.

**Table 5-3.**

<b>Maximum Particle Velocity In./sec.</b>	<b>Transient Motion, No Sound Effects, Impartial Observer</b>	<b>Blasting Accompanied by Sound Effects, Biased Observer</b>
<b>0-0.02</b>	<b>“Not noticed”</b>	<b>“Not noticed”</b>
<b>0.02-0.06</b>	<b>“Not noticed”</b>	<b>“Noticed, complaints possible”</b>
<b>0.06-0.20</b>	<b>“Noticed”</b>	<b>“Noticed, complaints possible”</b>
<b>0.20-0.40</b>	<b>“Noticed”</b>	<b>“Severe, complaints likely”</b>
<b>0.40-1.20</b>	<b>“Disturbing”</b>	<b>“Severe, complaints likely”</b>
<b>1.20-2.00</b>	<b>“Severe”</b>	<b>“Severe, complaints likely”</b>

Mine operators often receive blasting complaints from neighbors even though they are well within ground vibration and air overpressure limits being enforced by DMM. This can often be attributed to the fact that most homeowners are not knowledgeable about blasting; therefore, their concerns may be alleviated by meeting with them to discuss how blasts are designed to minimize effects, and how structure response from blasting compares with other sources such as closing doors, loud traffic, etc. In addition, mine operators can request technical assistance from DMM in addressing blasting concerns by neighbors.

Bureau of Mines indicates that one of the motivations for these levels were human irritation with, and tolerance of, repeated blasting operations. The Bureau of Mines established a 1.0 in./sec criteria for commercial surface mining blasting in the proximity of human habitation and DMM adopted this as well (4 VAC 25-40-880). Also, DMM has adopted criteria to permit alternate use of the maximum allowable velocity-frequency chart (4 VAC 25-40-880.C.). The design engineer or equivalent should consider the age of the structures, the condition of the structure, the type of blasting (construction or quarry), and pick a threshold value consistent with the expected frequency content of the motion and the appropriate level of risk of damage.

Many mine operators prefer to seismograph every blast. Seismograph recordings are very useful in understanding and troubleshooting ground vibration problems. Seismograph records provide excellent evidence in case of later complaints or damage lawsuits.

A seismograph is a special instrument that is used to measure particle motion that is associated with stress waves. The velocity type seismograph is the most widely used type for measuring ground motion generated by blasting operations. The velocity type seismograph records particle velocity of the stress wave at a particular location. Particle velocity is the rate of change in the stress wave amplitude as a function of time. A seismograph will record the particle motion of stress waves in three mutually perpendicular directions. The three directions are longitudinal or horizontal, transverse, and vertical. Most seismographs are normally constructed to measure particle velocities ranging from .1 to 10 inches per second over a frequency range of 2 to 200 hertz or cycles per second.

### **Blasting Restrictions – Air Overpressure and Ground Vibration**

DMM Safety & Health Regulations establish limits for air overpressure and ground vibration measured at inhabited buildings not owned or leased by the mine operator. The limit for airblast is 133 decibels, as measured with a 2 Hz or lower flat response microphone, at any inhabited building not owned or leased by the operator. (4 VAC 25-40-890)

The U. S. Bureau of Mines studied blasting vibration for most of the last century, and their studies indicated that the best measurement unit for vibration was the velocity of the ground movement. In the 1970's, the Bureau proposed vibration limits that depended on the distance from structures to the blast. These limits were selected to prevent damage to structures, and have been widely adopted. Numerous studies done since then have proven the validity of that standard, and the Division of Mineral Mining regulations are based on that work. DMM blasting limits range from 0.75-1.25 inches/second, when based solely on the distance from the blast to the nearest structure. (4 VAC 25-40-880.A.)

In addition, research has found that the frequency of ground vibrations also affects structures. These frequencies are measured in cycles per second, just like radio waves or musical notes. If the blasting frequencies are very low (in the 6-12 cycles per second range), they can match the natural frequency of a structure, and increase the vibration of that structure. This effect is addressed in the regulations by a graph that changes the maximum allowable ground vibration velocity as a function of the frequency (Figure 5-4). Basically, this graph allows a variation in the allowable ground vibration velocities as the frequency of that ground vibration increases, from a minimum of 0.2 inches per second up to a maximum of 2.0 inches per second. (4 VAC 25-40-880.C.)

With the exception of very low energy blast events, the mine operator is required to measure ground vibrations using a seismograph, at the closest structure to the blast site that the company does not own. The information is required to be kept by the operator for at least 3 years. (4 VAC 25-40-880.B.)

If necessary to prevent damage the DMM Director may specify lower allowable ground vibration and air overpressure limits (4 VAC 25-40-895). It is important that the mine operator inform the certified blaster responsible for designing the blast the method of compliance being used, or any other restrictions imposed by DMM or local authorities

## **Flyrock**

DMM Safety & Health Regulations state that the design and loading of a blast shall provide sufficient burden, spacing, and stemming to prevent flyrock or other dangerous effects (4 VAC 25-40-800 D.) Flyrock occurs when blasting operations result in flying rock fragments or missiles, which have the capacity to damage a structure or injure a person. Flyrock is more of a problem in highly fractured rock than in massive rock.

Flyrock means any uncontrolled material generated by the effects of a blast that is hazardous to persons or to property not owned or controlled by the operator. It represents a serious hazard to both mine employees and other persons who may be located at, or near the mine.

DMM Safety and Health Regulation 4 VAC 25-40-800.D. requires the certified blaster and mine operator to report flyrock incidents immediately to DMM and to note details in the blast record.

For the blaster in charge, the mention of flyrock conjures images of confrontations with neighbors and regulatory agencies. Investigations of flyrock incidents in Virginia have often revealed one or more of the following contributing factors:

1. Angled boreholes with varying amounts of burden along the length of the borehole;
2. Shallow boreholes (snake-holes) in toe of free-face with insufficient stemming;
3. Inadequate burden for the diameter of borehole drilled;

**Figure 5-4. Alternative Blasting Level Criteria**

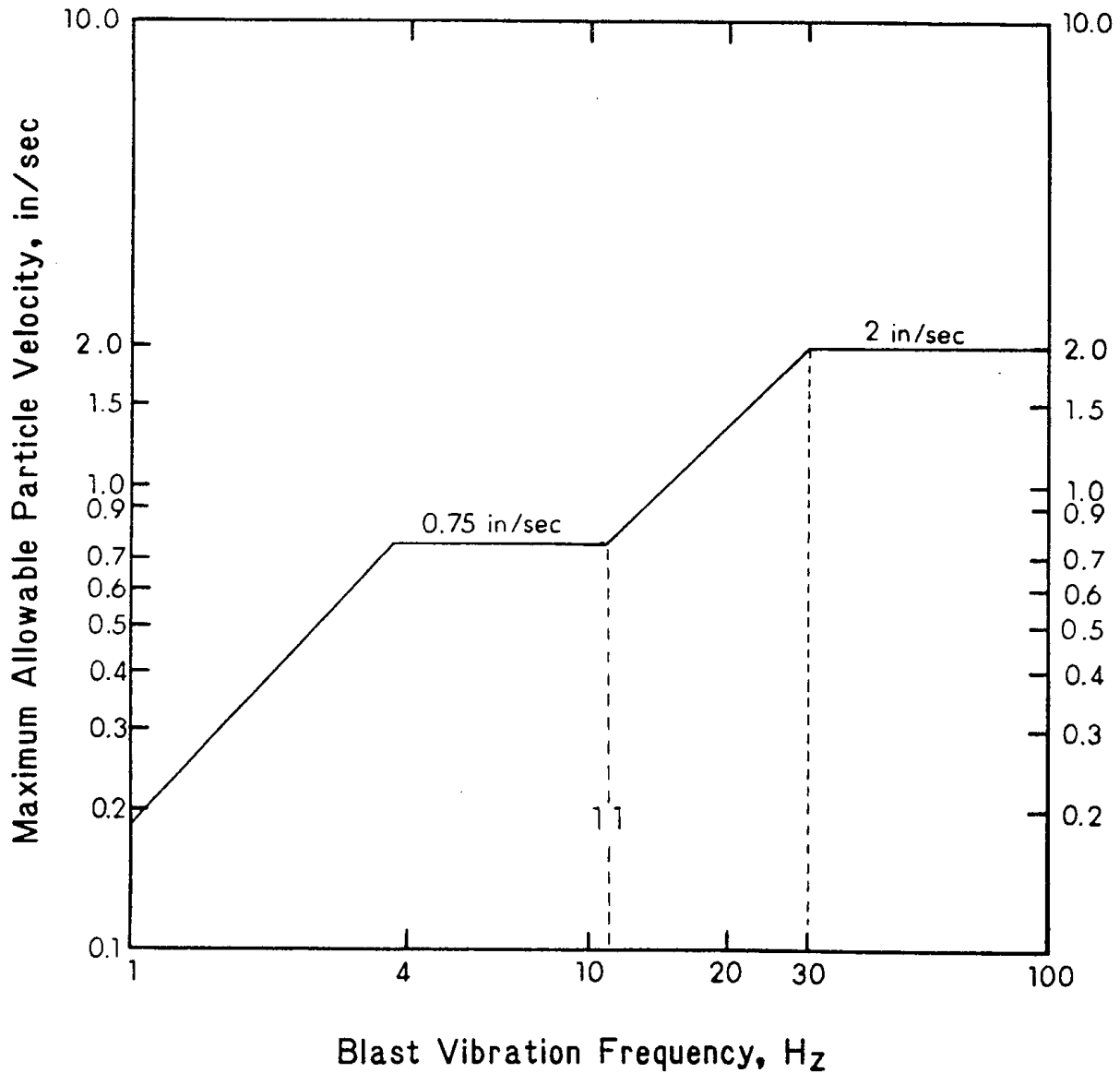

4. Insufficient stemming for borehole depth and burden;
5. Overloaded boreholes where loading density exceeded rock density of burden;
6. Inadequate controls during secondary blasting of boulders.

It is the certified blaster's responsibility to design the blast with sufficient burden and stemming to prevent flyrock or other dangerous effects. Blasters must give careful consideration to:

1. Evaluation of geologic conditions of material to be blasted;
2. Design of drill pattern;

3. Design of detonation sequence;
4. Calculation of powder factors for variable burden on front row of boreholes;
5. Compliance with ground vibration and air overpressure limits imposed by DMM or local government;
6. Sensitivity of neighbors to effects (noise/vibration) of blasting;
7. Use of good judgment by the blaster when using the arts/sciences of blasting.
8. Blasting has been, and continues to be, both an art and a science that relies heavily upon good judgement by the certified blaster in charge.

The mineral mine community in Virginia has experienced numerous flyrock incidents since March 2005. All of these incidents had the potential to cause serious personal injury to mine workers and citizens. Fortunately, no one was injured, though significant property damage (vehicles and structures) did occur in each of these incidents. The occurrence of flyrock can be considered an “imminent danger”, and result in the issuance of a Closure Order to the operator.

Blasters now have a wide variety of initiation devices and explosive products that allow for safe, effective blasting. The certified blaster is responsible for safe blasting. He must carefully evaluate the conditions, design the shot, supervise the loading, and ensure the safety of miners and the public during detonation.

## **SECTION 6**

### **STATE LAW AND REGULATIONS APPLICABLE TO SURFACE BLASTING CERTIFICATION**

This page intentionally left blank.

## **SECTION 6 – STATE LAW AND REGULATIONS APPLICABLE TO SURFACE BLASTING CERTIFICATION**

- Mineral Mine Safety Laws of Virginia
- Safety and Health Regulations for Mineral Mining

*[This section is designed to assist the prospective surface blaster in study and preparation for certification. Much of the knowledge necessary for the blaster certification examination as well as practical applications in blasting operations are detailed in two documents (1) The Mineral Mine Safety Laws of Virginia and (2) Safety and Health Regulations for Mineral Mining. You will need to study/use these two documents directly in familiarizing yourself with their content. A summary of the main areas you should focus on follows in an effort to condense and clarify the points of information that are most important.]*

# STATE LAW AND REGULATIONS APPLICABLE TO SURFACE BLASTING CERTIFICATION

## Applicable Areas of the Mineral Mine Safety Act

Certified Surface Blasters need to possess a general knowledge of the Virginia Mineral Mine Safety Act in order to understand and comply with the laws as they apply to mineral mining operations and to safety and health considerations. Specifically, Certified Surface Blasters should be knowledgeable of the mineral mining laws as they apply to their certification, duties, and responsibilities.

It is advisable for any individual who plans to obtain certification as a Surface Blaster-Mineral Mining to study and acquaint themselves fully with the following Articles under Chapter 14.4:1 of Virginia's Mineral Mine Safety Act. **(You should refer directly to the Mineral Mine Safety Laws of Virginia – specific Articles and Sections – for study.)**

### Main Points – Mineral Mine Safety Laws (2008 Edition)

*(Pages cited refer to Law Book)*

#### **Article 1: General Provisions.....pgs. 9-14**

- Definitions (pgs. 9-13)\*
- Persons not permitted to work in mines (pg. 13)
- Prohibited Acts by Miners or other persons; miners to comply with Law (pg. 13)
- Safety Materials and Supplies (pgs. 13-14)
- Notifying Miners of Violations; Compliance with Act (pg. 14)

**Definitions\*** - Know the terms and their meaning as used in the Laws (these same terms also apply as used in the Safety and Health Regulations for Mineral Mining)

*\*surface blasters will not be held responsible for knowing Underground Mining terminology*

Surface Blasting Certification applicants should be familiar with certain areas of Article 1 -- General Provisions, including the standards concerning safety and health of miners, persons not permitted to work in mines, prohibited acts by miners and miners' compliance with laws, safety materials and supplies requirements, and notification of miners of violations and compliance with the Act.

#### **Article 3: Certification of Mineral Mine Workers.....pgs. 15-20**

- General Knowledge and Understanding of entire Article is Advisable
- Special attention to Revocation of certificates (pg. 19)

Surface Blasting Certification applicants need to have general knowledge of Article 3. This Article deals with the Board of Mineral Mine Examiners; covering structure, functions, and powers of the Board. This Article also covers certifications required of certain persons employed in mineral mines, certification examinations (and exam fees), penalties under the law

for performance of certain tasks by uncertified persons, certification reciprocity, and renewal requirements and reexamination procedures. Specific Sections of this Article address requirements for General Mineral Miner Certification and Foreman Certification.

**Article 4: Licensing of Mineral Mines .....pgs. 20-26**

- Independent Contractor Information Required (which includes contract blasters and drillers) to be filed on license application (Item 3 under section 45.1 –161.292.32 (pg. 22)
- Making false statements; penalty (pg. 26)

Attention should be given to this Article, mainly for an understanding of Section 45.1.161.292:39, which addresses “Making false statements; penalty.” This section could apply in any situation where duties, information, or records are applicable in a certified blaster’s capacity.

**Article 6: Mine Explosions; Mine Fires; Accidents ..... pgs. 29-30**

- General Knowledge and Understanding of Entire Article is Advisable
- Special Attention to Operator’s reports of Accidents; investigations and reports of other accidents and injuries (pgs. 29-30)

Surface Blasting Certification applicants need to know the State requirements for mineral mines applicable to reporting mine explosions, mine fires, and accidents. Responsibilities of mine operators involving investigations, reports, and records are defined in Article 6. Duties of mine inspectors and procedures that apply to the Division of Mineral Mining related to these topics are also outlined in this Article.

**Article 7: Mine Inspections .....pgs. 30-33**

- General Knowledge and Understanding of Entire Article is Advisable

This Article contains numerous requirements that a Certified Surface Blaster applicant should generally be aware of. Mine inspection frequencies, risk evaluations at mineral mines, duties of operators and inspectors related to mine inspections and denial of entry (of mine inspectors) standards are major areas of importance in Article 7.

**Article 8: Enforcement and Penalties; reports of violations.....pgs. 33-37**

- General knowledge and Understanding of Entire Article is Advisable
- Pay close attention to requirements under Notices of Violations (45.1-161.292:63.B.) – pgs. 33-34 and Reports of Violations (45.1-161.292:70.) – pgs. 36-37

Article 8 details laws relating to DMM’s issuance of Notices of Violations and Closure Orders and how the process works, including such items as tolling time for abatement of

violations, injunctive relief, penalty for willful violation of the provisions, prosecution of violations, and reports of violations. All of the preceding items represent areas of the law that a Certified Blaster applicant will want to review and understand in the process of becoming certified.

**Article 9: Miner Training.....pg. 37**

- Mineral mining safety training program (pg. 37)

As a Certified Surface Blaster applicant, there are requirements in the area of Miner Training that you should be aware of. In addition to the General Mineral Miner certification previously covered in Article 3, Article 9 outlines requirements for safety training programs (plans) for new miner, newly-employed experienced miners, training of miners for new tasks, annual refresher training, and hazard training. Knowing the training required and to whom it applies is information all certified persons should be familiar with. Each mine operator and independent contractor must have a safety training plan that contains the elements listed in 45.1-161.292:73.

**Applicable Areas of the Safety and Health Regulations for Mineral Mining**

**Main Points – Virginia Division of Mineral Mining’s Safety and Health Regulations**

Title 4 (Conservation and Natural Resources) of Virginia’s Administrative Code contains the Department of Mines, Minerals and Energy’s Division of Mineral Mining’s Safety and Health Regulations. Chapter 40 contains 16 Parts, 14 of which apply to both surface and underground mineral mining operations. Part XV is applicable to underground mines only and Part XVI addresses Mining near Gas and Oil Wells. Also incorporated into the Mineral Mining Safety and Health Regulation Booklet is Chapter 35 of the Virginia Administrative Code – this contains rules of the Board of Mineral Mining Examiner’s addressing the Certification Requirements for Mineral Miners.

Because your main objective is to prepare to become certified as a Surface Blaster, the most important Parts of the Safety and Health Regulations (for this purpose) are Part VI – Explosives, and Part VII – Drilling. Because these relate directly to the subject of blasting, you will want to know every detail for exam purposes and more importantly, so you can maintain compliance with the regulations at the mine once you become certified.

A large percentage of the other Safety and Health Regulations are also important knowledge for the certified surface blaster. On the practical side, every single requirement exists because of operational or safety related problems, accidents, or injuries that have occurred when rules such as these were not followed.

In summary, many of the regulations are specific to drilling and blasting and apply directly to the work and practices that a certified surface blaster performs (or oversees). Many other regulations may apply indirectly, and simply address sound operational, health and safety, and accident prevention practices that are pertinent to everyone who works in the mineral mining industry.

- **Chap. 35 – Certification Requirements for Mineral Miners**

Chapter 35 is contained in the 2007 edition of the Safety and Health Regulations. These requirements stand alone and represent all specifics concerning who, how, and what is necessary to become certified by the Board of Mineral Mine Examiners. These regulations are current as of July 2009. A complete copy of the Certification Requirements for Mineral Miners may be obtained at the following link: <http://leg1.state.va.us/000/1st/h2863412.HTM>.

Part I of Virginia’s Board of Mineral Mine Examiners Certification Requirements for Mineral Miners clearly defines all specifics for becoming certified; including examination requirements, reciprocity, and renewal of certifications.

Part II addresses Minimum Certification Requirements in the different certification areas required by the Board. These include Underground Foreman, Surface Foreman, Surface Foreman-Open Pit, Surface Blaster, Underground Mining Blaster, Mineral Mine Electrician, Mine Inspector, and General Mineral Miner.

Prospective Surface Blasters will want to be familiar with these regulations in general, and will be exposed to the requirements and processes as they apply for their certification and continued renewals through their careers.

- **Chap. 40 – Safety and Health Regulations for Mineral Mining**

The Safety and Health Regulations for Mineral Mining were updated in 2009, with the updated regulations effective July 8, 2009. A copy of the complete Safety and Health Regulations may be obtained at the following link: <http://leg1.state.va.us/000/1st/h2862937.HTM>.

### **Part I – General Administrative Provisions**

#### 4 VAC 25-40-10 – Definitions

**Reminder:** Terms defined in Title 45.1- Article 1 of the Mineral Mine Safety Laws that are used in the Safety and Health Regulations retain their meaning. These terms are not listed and defined again in the definitions section of the regulations, but you will be responsible for knowing them from your study of the Laws.

The following are all important terms to know, as listed and defined in Part I of the Safety and Health Regulations, as you prepare to become a certified surface blaster: (terms specific to blasting are in **bold print** for emphasis)

“Abandoned mine”	“ <b>Burden</b> ”	“Flash point”
“Abandoned workings”	“Company official”	“ <b>Free-face</b> ”
“ <b>Acceptable</b> ”	“Department”	“ <b>Flyrock</b> ”
“Angle of repose”	“Director”	“ <b>Heavy duty mobile equipment</b> ”
“ <b>Blast area</b> ”	“Division”	“Hoist”
“ <b>Blast site</b> ”	“Escapeway”	“ <b>Loaded</b> ”
	“Face” or “bank”	

“Major Electrical Installation”  
“Misfire”  
“MSHA”  
“Occupational Injury”  
“Overburden”  
“Potable”

“Powder chest”  
“Primer”  
“Refuse”  
“Rollover protection”  
“Safety fuse”  
“Safety hazard”  
“Scaled Distance (Ds)”  
“Scaling”

“Stemming”  
“Substantial Construction”  
“Suitable”  
“Switch”  
“Travelway”  
“Wet drilling”

Generally, surface blasters should be aware of the following Safety & Health Regulations, also found in PART I:

- 4 VAC 25-40-25 – Purpose and Authority
- 4 VAC 25-40-40 – Certification
- 4 VAC 25-40-50 – Duties of Mine Operators
- 4 VAC 25-40-70 – Approval Procedure
- 4 VAC 25-40-90 – Documents Incorporated by Reference

## **Part II– General Safety Provisions**

There are a number of items in Part II of the Safety & Health Regulations that Certified Surface Blasters should be know. From the standpoint of your prospective role as a certified person who may supervise others on the mine site, or in order to have a working knowledge of the regulations as they apply to safety and training requirements, the following sections should be reviewed and understood:

- 4 VAC 25-40-100 – Employee Training
- 4 VAC 25-40-110 – Inexperienced Employees
- 4 VAC 25-40-120 – When Foreman Required
- 4 VAC 25-40-130 – Examination by Foreman
- 4 VAC 25-40-140 – First Aid Training for Foreman
- 4 VAC 25-40-145 – Inspection of Mobile and Stationary Equipment
- 4 VAC 25-40-150 – Assignment of Persons to Hazardous Areas
- 4 VAC 25-40-160 – Emergency Medical Assistance
- 4 VAC 25-40-170 – Emergency Telephone Numbers

- 4 VAC 25-40-180 – Emergency Communications Systems
- 4 VAC 25-40-190 – Compliance with Regulations
- 4 VAC 25-40-200 – Illumination Requirements
- 4 VAC 25-40-210 – Cleanliness
- 4 VAC 25-40-220 – Water Supplies
- 4 VAC 25-40-230 – Toilet Facilities
- 4 VAC 25-40-250 – Use of Intoxicating Substances
- 4 VAC 25-40-260 – Posting Hazards
- 4 VAC 25-40-280 – Horseplay Prohibited
- 4 VAC 25-40-330 – Proper Use of Machinery
- 4 VAC 25-40-350 – Repairing Machinery
- 4 VAC 25-40-360 – Maintaining Machinery

### **Part III – Ground Control**

Certain regulations relating to Ground Control requirements have implications to blasting operations, therefore a certified blaster should know the basic content of Part III of the Safety and Health Regulations. These sections should be reviewed in order to understand the requirements and their practical application relating to proper operational and safety practices:

- 4 VAC 25-40-390 – Stability Requirements
- 4 VAC 25-40-400 – Open Pit Mine Rims
- 4 VAC 25-40-410 – Benches
- 4 VAC 25-40-420 – Scaling Hazardous Areas
- 4 VAC 25-40-430 – Hazardous Conditions
- 4 VAC 25-40-440 – Installation of Rock Bolts
- 4 VAC 25-40-450 – Correction of Unsafe Conditions
- 4 VAC 25-40-460 – Examination for Unsafe Conditions

4 VAC 25-40-470 – Keeping Clear of Equipment

4 VAC 25-40-480 – Trimming of Faces

#### **Part IV – Fire Prevention and Control**

Part IV also contains some requirements that a certified blaster should be familiar with. Fire Prevention, protection, and control in mineral mining are extremely important considerations for all miners. Again, because of leadership and operational responsibilities that fall on the shoulders of the Certified Surface Blaster, the following sections of Part IV of the Health and Safety Regulations should be reviewed thoroughly:

4 VAC 25-40-490 – Smoking Near Flammable and Combustible Materials

4 VAC 25-40 500 – Warning and Evacuation Procedures

4 VAC 25-40-520 – Storage of Flammable Materials

4 VAC 25-50-560 – Solvents

4 VAC 25-40-570 – Waste Materials

4 VAC 25-40-580 – Use of Flammable Liquids for Cleaning

4 VAC 25-40-610 – Fire Equipment

4 VAC 25-40-630 – Training and Practice Drills

4 VAC 25-40-640 – Firefighting Assistance

4 VAC 25-40-670 – Fire Extinguishers

#### **Part V – Air Quality and Physical Agents**

All Sections

Airborne contaminant exposure limits, dust source control, silica compounds limitations and noise exposure limits are addressed in Part V of the Safety and Health Regulations. This brief Part, in its entirety should be reviewed for understanding, as it does have implications to surface blasting practices at mineral mine sites.

#### **Part VI – Explosives**

All Sections (Note that significant changes went into effect July 8, 2009)

## **Part VII – Drilling**

All Sections (Note that significant changes went into effect July 8, 2009)

**Review and be knowledgeable of every detail of all sections of Parts VI and VII** of the Safety and Health Regulations. These regulations address requirements in the certification area that you are seeking and every single item is important, in terms of potential examination material and the practical knowledge necessary to perform as a Certified Surface Blaster. There were significant changes to Parts VI and VII that went into effect July 8, 2009.

## **Part VIII – Compressed Air, Gases, and Boilers**

Certain sections of this Part VIII of the Safety and Health Regulations should be reviewed. While direct applicability to blasting is minimal, you should be aware of the following sections:

4 VAC 25-40-1100 – Boilers and Pressure Vessels

4 VAC 25-40-1110 – Air Compressors

4 VAC 25-40-1120 – Compressed Air Receivers

4 VAC 25-40-1190 – Repairs

4 VAC 25-40-1200 – Improper Use of Compressed Air

4 VAC 25-40-1210 – Locking Devices

## **Part IX – Mobile Equipment**

It is difficult to work at a surface mineral mine without operating or otherwise interacting in some way with the use of mobile equipment of some type. Nationally, and in Virginia, mobile (powered haulage) equipment accidents continue to be one of the leading causes of serious injuries and fatalities in the mineral mining industry. For these reasons it is advisable for certified surface blasters to familiarize themselves with certain standards contained in the Safety and Health Regulations.

4 VAC 25-40-1320 – Brakes on Mobile Equipment

4 VAC 25-40-1330 – Emergency Brakes

4 VAC 25-40-1340 – Requirements for Starting or Moving Equipment

4 VAC 25-40-1350 – Construction of Operators' Cabs

4 VAC 25-40-1370 – Safety Equipment

- 4 VAC 25-40-1380 – Extraneous Materials in Cabs
- 4 VAC 25-40-1390 – Operating Speeds
- 4 VAC 25-40-1410 – Restraining Berms or Guards
- 4 VAC 25-40-1420 – Operation under Power Control
- 4 VAC 25-40-1430 – Maintaining Control of Equipment
- 4 VAC 25-40-1460 – Prohibited Means of Transportation
- 4 VAC 25-40-1470 – Securing Equipment in Travel Position
- 4 VAC 25-40-1510 – Setting Brakes
- 4 VAC 25-40-1540 – Traffic Rules
- 4 VAC 25-40-1550 – Heating and Cooling Cabs
- 4 VAC 25-40-1570 – Audible Warning Devices
- 4 VAC 25-40-1580 – Backup Alarms
- 4 VAC 25-40-1600 – Avoiding Mobile Equipment in Operation

## **Part X – Personal Protection**

### All Sections

Proper personal protective equipment for miners is an important safety measure. As a certified person who may be in charge of other workers, it is important that you understand such requirements and assume responsibility for assuring that all personnel are using (wearing) proper Personal Protective Gear that is in good and functional condition. These include such basic items as safety harnesses, hard hats, protective footwear, safety glasses or goggles, and gloves.

Part X has other related requirements that address personal protection, including sections that cover First Aid material availability, finger ring(s) prohibition when working with tools/equipment, light reflective material requirements for night visibility of persons, loose clothing hazards and protection from falling (or engulfing) material at dump sites.

While all sections of Part X may not apply directly to blasting work, there are numerous important items that apply to all miners. *Review and be knowledgeable of all requirements in Part X.*